



ANT95LZS Series Single-Axis Z Low-Profile Direct-Drive Nanopositioning Stage

HARDWARE MANUAL

Revision 2.01



GLOBAL TECHNICAL SUPPORT

Go to the [Global Technical Support Portal](#) for information and support about your Aerotech, Inc. products. The website supplies software, product manuals, Help files, training schedules, and PC-to-PC remote technical support. If necessary, you can complete Product Return (RMA) forms and get information about repairs and spare or replacement parts. To get help immediately, contact a service office or your sales representative. Include your customer order number in your email or have it available before you call.

This manual contains proprietary information and may not be reproduced, disclosed, or used in whole or in part without the express written permission of Aerotech, Inc. Product names mentioned herein are used for identification purposes only and may be trademarks of their respective companies.

Copyright © 2020-2022, Aerotech, Inc., All rights reserved.



Table of Contents

ANT95LZS Series Single-Axis Z Low-Profile Direct-Drive Nanopositioning

Stage	1
Table of Contents	3
List of Figures	4
List of Tables	5
EU Declaration of Incorporation	7
Safety Procedures and Warnings	8
Installation and Operation	9
Electrical Warnings	10
Motor-Related Warnings	11
Pinch Points	12
Magnetic Hazards	13
Handling and Storage	14
Chapter 1: Overview	17
1.1. Environmental Specifications	18
1.2. Accuracy and Temperature Effects	18
1.3. Basic Specifications	19
1.4. Air Requirements	20
Chapter 2: Installation	21
2.1. Dimensions	21
2.2. Securing the Stage to the Mounting Surface	22
2.2.1. Setting up the Pneumatic Counterbalance	24
2.3. Attaching the Payload to the Stage	26
Chapter 3: Electrical Installation	29
3.1. Motor and Feedback Connectors	30
3.2. Motor and Feedback Wiring	32
3.3. Motor and Feedback Specifications	33
3.4. Limits, Marker, and Machine Direction	35
3.5. Motor and Feedback Phasing	36
Chapter 4: Maintenance	39
4.1. Service and Inspection Schedule	39
4.2. Cleaning and Lubrication	40
4.3. Troubleshooting	42
Appendix A: Warranty and Field Service	43
Appendix B: Revision History	45
Index	47

List of Figures

Figure 1-1: Counterbalance Air Flow vs. Counterbalance Pressure	20
Figure 1-2: Air Inlet Location	20
Figure 2-1: ANT95LZS Dimensions	21
Figure 2-2: Mounting Hole Pattern	23
Figure 2-3: Counterbalance Pressure vs. External Payload	24
Figure 2-4: Load Orientations	27
Figure 2-5: Cantilevered Load Capabilities	28
Figure 3-1: ANT95LZS Motor and Feedback Wiring	32
Figure 3-2: Machine Direction	35
Figure 3-3: Hall Phasing Diagram	36
Figure 3-4: Encoder Phasing Reference Diagram (Standard/Square Wave)	37
Figure 3-5: Encoder Phasing Reference Diagram (Analog/Sine Wave)	37

List of Tables

Table 1-1: Model Numbers and Ordering Options	17
Table 1-2: Environmental Specifications	18
Table 1-3: ANT95LZS Series Specifications	19
Table 2-1: Stage Mounting Surface Flatness Requirement	22
Table 2-2: Stage to Mounting Surface Hardware	23
Table 2-3: Payload to Stage Surface Hardware	26
Table 3-1: 25-Pin Motor and Feedback Connector Pinout	31
Table 3-2: 25-Pin Mating Connector Part Numbers	31
Table 3-3: Hall-Effect Sensor Specifications	33
Table 3-4: Thermistor Specifications	33
Table 3-5: Encoder Specifications	33
Table 3-6: Limit Switch Specifications	33
Table 3-7: ANT95LZS Motor Specifications	34
Table 3-8: Encoder Resolution	34

This page intentionally left blank.

EU Declaration of Incorporation

Manufacturer Aerotech, Inc.
101 Zeta Drive
Pittsburgh, PA 15238-2811
USA

herewith declares that the product:

ANT95LZS Linear Stage

is intended to be incorporated into machinery to constitute machinery covered by the Directive 2006/42/EC as amended;

and that the following harmonized European standards have been applied:

EN ISO 12100:2010

Safety of machinery - Basic concepts, general principles for design

EN 60204-1:2010

Safety of machinery - Electrical equipment of machines - Part 1: General requirements

and further more declares that

it is not allowed to put the equipment into service until the machinery into which it is to be incorporated or of which it is to be a component has been found and declared to be in conformity with the provisions of the Directive 2006/42/EC and with national implementing legislation, for example, as a whole, including the equipment referred to in this Declaration.

This is to certify that the aforementioned product is in accordance with the applicable requirements of the following directive(s):

2011/65/EU
EU 2015/863

RoHS 2 Directive
Amendment RoHS 3 Directive

Authorized Representative



/ Simon Smith, European Director

Aerotech Ltd
The Old Brick Kiln, Ramsdell, Tadley
Hampshire RG26 5PR
UK

Engineer Verifying Compliance



/ Alex Weibel

Aerotech, Inc.
101 Zeta Drive
Pittsburgh, PA 15238-2811
USA
3/24/2022

Date



Safety Procedures and Warnings

IMPORTANT: This manual tells you how to carefully and correctly use and operate the stage.



- Read all parts of this manual before you install or operate the stage or before you do maintenance to your system.
- To prevent injury to you and damage to the equipment, obey the precautions in this manual.
- All specifications and illustrations are for reference only and were complete and accurate as of the release of this manual. To find the newest information about this product, refer to www.aerotech.com.

If you do not understand the information in this manual, contact Aerotech Global Technical Support.

IMPORTANT: This product has been designed for light industrial manufacturing or laboratory environments. If the product is used in a manner not specified by the manufacturer:



- The protection provided by the equipment could be impaired.
- The life expectancy of the product could be decreased.

Safety notes and symbols are placed throughout this manual to warn you of the potential risks at the moment of the safety note or if you fail to obey the safety note.



Shock/Electrocution Hazard Warning



General or Conditional Awareness Warning



Hot Surface Hazard Warning



Magnetic Field Hazard Warning



Mechanical Shearing, Pinching, or Crushing Hazard Warning



Heavy, Bulky Lifting Hazard / Appropriate Equipment Required Warning



Trip Hazard Warning



A blue circle symbol is an action or tip that you should obey. Some examples include:



- General tip
- Read the manual/section
- Wear protective safety equipment (eye protection, ear protection, gloves)
- If applicable, do not lift unassisted

Installation and Operation

To decrease the risk of damage to the equipment, you must obey the precautions that follow.



DANGER: General Hazard Warning!

This product can produce high forces and move at velocities that could cause injury. The user is responsible for its safe operation. The following general equation is provided to assist with risk assessments in regards to contact and pinch points:

$$Pressure_{Max} \left[\frac{N}{mm^2} \right] = \frac{Force_{Peak} [N]}{Area_{Contact} [mm^2]}$$



WARNING: General Hazard Warning!

- Only trained operators should operate this equipment.
- All service and maintenance must be done by approved personnel.
- Use this product only in environments and operating conditions that are approved in this manual.
- Never install or operate equipment that appears to be damaged.
- Make sure that the product is securely mounted before you operate it.
- Use care when you move the ANT95LZS or you could negatively affect the performance of it.



WARNING: Trip Hazard!

Route, house, and secure all cables, duct work, air, or water lines. Failure to do so could introduce trip hazards around the system that could result in physical injury or could damage the equipment.

Electrical Warnings

To decrease the risk of electrical shock, injury, death, and damage to the equipment, obey the precautions that follow.



DANGER: Electrical Shock Hazard!

- Stage motor phase voltage levels could be hazardous live.
- Personnel are protected from hazardous voltages unless electrical interconnections, protective bonding (safety ground), or motor/stage enclosures are compromised.
- Do not connect or disconnect stage/motor interconnections while connected to a live electrical power source.
- Before you set up or do maintenance, disconnect electrical power.
- It is the responsibility of the End User/System Integrator to make sure that stages are properly connected and grounded per Engineering Standards and applicable safety requirements.
- It is the responsibility of the End User/System Integrator to configure the system drive or controller within the Aerotech motor/stage electrical and mechanical specifications.

Motor-Related Warnings

Aerotech motors are capable of producing high forces and velocities. Obey all warnings and all applicable codes and standards when you use or operate a stage or system that incorporates Aerotech motors.



DANGER: Hot Surface Hazard!

- The stage/motor frame temperature could exceed 70°C in some applications.
- Do not touch the stage/motor frame while it is in operation.
- Wait until the stage/motor has cooled before you touch it.



DANGER: Risk of Explosive Atmosphere!

- Standard Aerotech stage/motors are not rated for applications with explosive atmospheres such as air-borne dust or combustible vapors.
- Do not operate stage/motors outside of Aerotech environmental specifications.



DANGER: Mechanical Hazard!

Personnel must be made aware of the mechanical hazards during set up or when you do service to the stage.

- When the system is not electrically energized (disabled), linear stage/motors can still allow a stage carriage to move freely. This can create mechanical hazards such as pinch or crush points.
- Unintentional manual movement into the stage "end-of-travel" stops, could damage the stage or undo precision alignments.



DANGER: Magnetic Field Hazard!

Aerotech stage/motors contain magnets which can present a Magnetic Field Hazard.

- Do not disassemble a stage motor under any circumstances.
- Strong magnetic fields could interfere with external/internal medical devices.
- Strong magnetic fields could present mechanical hazards such as pinch points.

Pinch Points

A pinch point is a mechanical hazard that can occur when there are exposed parts of the stage or system that can move. For example, the travel of a stage tabletop could expose the user to a pinch point between the tabletop and the stage housing. The images that follow will show you typical external and internal pinch point locations.

DANGER: Mechanical Hazard!



- System travel can cause crush, shear, or pinch injuries.
- Only trained operators should operate this equipment.
- Do not put yourself in the travel path of machinery.
- Restrict access to all motor and stage parts
 - when the system moves under power (during normal operation, for example).
 - when the system is moved manually (during the installation process or when you do maintenance, for example).
- Motors are capable of very high speeds and acceleration rates.

Figure 1: Typical Pinch Point Locations

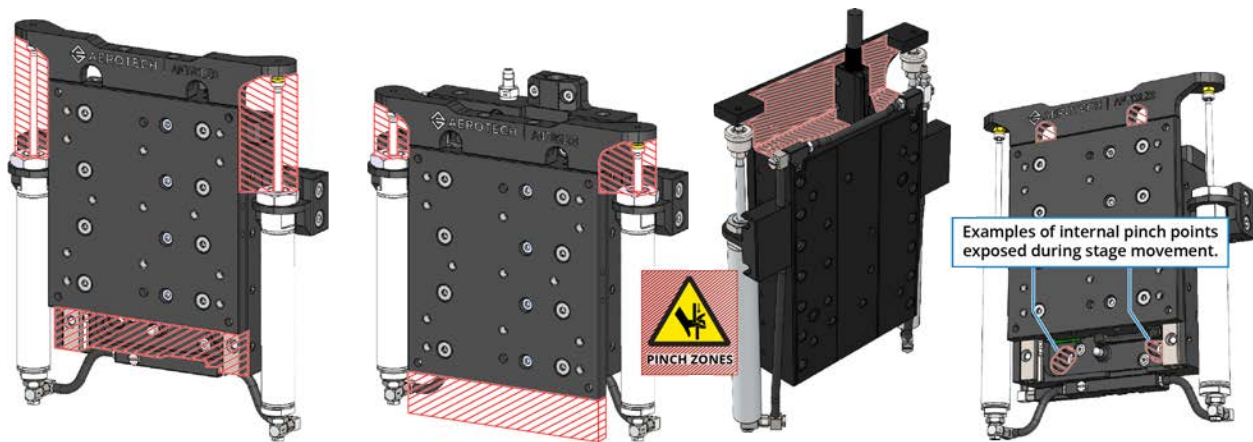

Magnetic Hazards

The magnet track will be exposed during normal operation or when you do maintenance to the system.



DANGER: Magnetic Field Hazard!

- Only qualified, trained personnel should be allowed to have access to exposed magnet tracks during setup or when you do maintenance.
- Strong magnetic fields are present near and inside the magnet track assembly.
- Do not disassemble the magnet track components. If you do so, you will expose yourself to mechanical crush, pinch, or impact hazards.
- Magnetic fields could interfere with external or internal medical devices (pace-makers, for example).
- Magnetic fields can create mechanical hazards (crush, impact, or pinch points, for example).
- Loose items such as metallic tools, watches, or keys could get drawn into and damage the magnet track assembly.



IMPORTANT: Use non-magnetic tools when you install or do service to the stage.

Figure 2: Exposed Magnet Locations

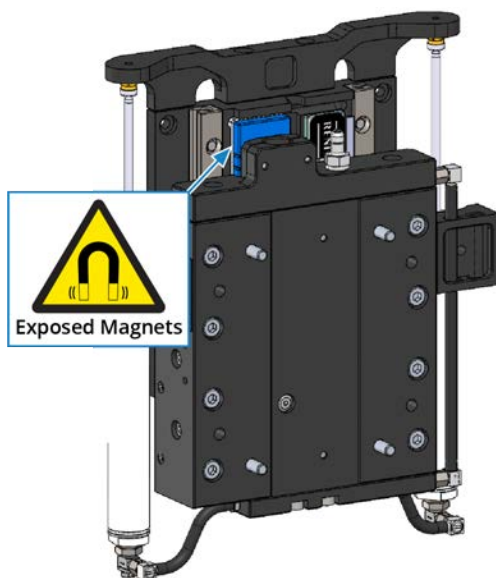

Handling and Storage



IMPORTANT: It is the responsibility of the customer to safely and carefully lift and move the stage.

- Be careful when you move or transport the stage.
- Retain the shipping materials for future use.
- Transport or store the stage in its protective packaging.



WARNING: Electrostatic Discharge (ESD) Sensitive Components!

Wear an ESD wrist strap when you handle, install, or do service to the system assembly. You could damage the power supply or drives if you fail to observe the correct ESD practices.

Inspect the shipping container for any evidence of shipping damage. If any damage exists, notify the shipping carrier immediately.

Remove the packing list from the shipping container. Make sure that all the items specified on the packing list are contained within the package.

The documentation for the stage is on the included installation device. The documents include manuals, interconnection drawings, and other documentation pertaining to the system. Save this information for future reference.

Each stage has a label listing the system part number and serial number. These numbers contain information necessary for maintenance or system hardware and software updates. Locate this label and record the information for later reference.

Unpacking and Handling

It is the responsibility of the customer to safely and carefully lift and move the stage.



IMPORTANT: All electronic equipment and instrumentation is wrapped in antistatic material and packaged with desiccant. Ensure that the antistatic material is not damaged during unpacking.



DANGER: Heavy Object, Lifting Hazard!

- Refer to [Section 2.1. Dimensions](#) for dimensions and [Section 1.3. Basic Specifications](#) for weight specifications.
- Use care when you move the ANT95LZS or you could negatively affect the performance of it.
- Lift this product only by the base.
- For multi-axis assemblies, always lift the system by the lower axis.
- Do not use the cables or the connectors to lift or move this product.
- Make sure that all moving parts are secure before you move the stage. Unsecured moving parts could shift and cause injury or damage to the equipment.

Carefully remove the stage from its protective shipping container. Gently set the stage on a smooth, flat, and clean surface. Use compressed nitrogen or clean, dry, oil-free air to remove any dust or debris that has collected during shipping.

Before you operate the stage, let it stabilize at room temperature for at least 12 hours. This will ensure that all of the alignments, preloads, and tolerances are the same as they were when they were tested at Aerotech.

Each stage has a label listing the system part number and serial number. These numbers contain information necessary for maintenance or system hardware and software updates. Locate this label and record the information for later reference.

Red, anodized aluminum shipping brackets have been installed to prevent unwanted motion damage that could occur during shipment. The brackets must be removed before the ANT95LZS can be operated. Retain the brackets and hardware for future use.

**DANGER: Mechanical Hazard!**

- The product can move manually without electrical power connected.
- When the shipping brackets are removed, the operator could be exposed to pinch points.

Figure 3: Shipping Brackets

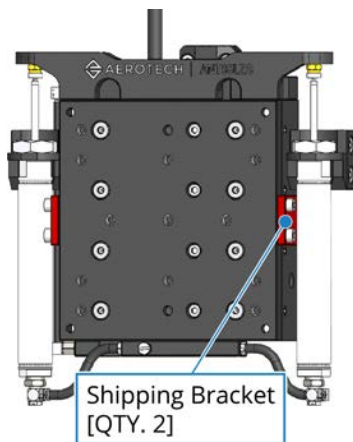
**Storage**

Store the stage in the original shipping container. If the original packaging included ESD protective packaging, make sure to store the stage in it. The storage location must be dry, free of dust, free of vibrations, and flat.

Refer to [Section 1.1. Environmental Specifications](#)

This page intentionally left blank.

Chapter 1: Overview

Table 1-1: Model Numbers and Ordering Options

ANT95LZS Single-Axis Z Direct-Drive Nanopositioning Stage	
Travel (Required)	
-025	25 mm travel
-050	50 mm travel
-075	75 mm travel
-100	100 mm travel
Feedback (Required)	
-E1	Incremental linear encoders, 1 Vpp amplified sine output
-E2	Incremental linear encoders, digital RS422 output, 5 nm electrical resolution
-E4	Incremental linear encoders, 1 Vpp amplified sine output, high-performance
Mounting Plate (Optional)	
-MP	Mounting plate
Performance Grade (Required)	
-PL1	Base performance
-PL2	High-accuracy performance
Integration (Required)	
-TAS	Test as system: Testing, integration, and documentation of a group of components as a complete system that will be used together.
-TAC	Test as components: Testing and integration of individual items as discrete components that ship together.

1.1. Environmental Specifications



WARNING: General Hazard Warning! Do not expose this product to environments or conditions outside of the listed specifications. You could damage the equipment if you exceed the environmental or operating specifications.



DANGER: Risk of Explosive Atmosphere!

- Standard Aerotech stage/motors are not rated for applications with explosive atmospheres such as air-borne dust or combustible vapors.
- Do not operate stage/motors outside of Aerotech environmental specifications.

Table 1-2: Environmental Specifications

Ambient Temperature	Operating: 10° to 35° C (50° to 95° F)
	The optimal operating temperature is 20° C \pm 2° C (68° F \pm 4° F). If at any time the operating temperature deviates from 20° C degradation in performance could occur.
Humidity	Storage: 0° to 40° C (32° to 104° F) in original shipping packaging
	Operating: 20% to 60% RH
	Storage: 10% to 70% RH, non-condensing in original packaging. The stage should be packaged with desiccant if it is to be stored for an extended time.
Altitude	Operating: 0 m to 2,000 m (0 ft to 6,562 ft) above sea level
	Contact Aerotech if your specific application involves use above 2,000 m or below sea level.
Vibration	Use the system in a low vibration environment. Excessive floor or acoustical vibration can affect system performance. Contact Aerotech for information regarding your specific application.
Protection Rating	These stages are not suited for dusty or wet environments. This equates to an ingress protection rating of IP00.
Use	Indoor use only

1.2. Accuracy and Temperature Effects

Aerotech products are designed for and built in a 20°C (68°F) environment. Extreme temperature changes could cause a decrease in performance or permanent damage to the stage. At a minimum, the environmental temperature must be controlled to within 0.25°C per 24 hours to ensure the stage specifications are repeatable over an extended period of time. The severity of temperature effects on all specifications depends on many different environmental conditions, which include how the stage is mounted. Contact the factory for more details.

The thermal expansion coefficient of the encoder scale is 3.25 ppm/°C. Travel will increase or decrease at this rate as the temperature of the encoder scale temperature deviates from 20°C (68°F).

The accuracy specification of stage is measured 25 mm above the table with the stage in an unloaded condition. The stage is assumed to be fully supported by a mounting surface meeting or exceeding the specification in [Section 2.2](#).

1.3. Basic Specifications

Resolution is dependent on encoder resolution and controller interpolation.

Table 1-3: ANT95LZS Series Specifications

		ANT95LZS-025	ANT95LZS-050	ANT95LZS-075	ANT95LZS-100
Travel		25 mm	50 mm	75 mm	100 mm
Accuracy ⁽¹⁾	-PL1	± 3.25 µm	± 3.25 µm	± 4.5 µm	± 5.5 µm
	-PL2 (-E1, -E2)	± 275 nm	± 275 nm	± 300 nm	± 300 nm
	-PL2 (-E4)	± 175 nm	± 175 nm	± 200 nm	± 200 nm
Bidirectional Repeatability ⁽¹⁾		± 75 nm			
Resolution (Minimum Incremental Motion)	-E1	2 nm			
	-E4	1 nm			
Straightness ⁽¹⁾		± 1.75 µm	± 1.75 µm	± 2.5 µm	± 3.0 µm
Flatness ⁽¹⁾		± 1.75 µm	± 1.75 µm	± 2.5 µm	± 3.0 µm
Pitch		10 arc sec			
Roll		10 arc sec			
Yaw		5 arc sec			
Maximum Speed		200 mm/s			
Maximum Acceleration (No Load)		1 g			
In-Position Stability ⁽²⁾	-E1	<2 nm			
	-E4	<1 nm			
Load Capacity (Vertical) ⁽³⁾		5 kg			
Moving Mass		0.50 kg	0.72 kg	0.85 kg	1.08 kg
Stage Mass		1.17 kg	1.63 kg	1.90 kg	2.40 kg
Material		Anodized Aluminum			
Mean Time Between Failure		30,000 Hours			
<p>1. Certified with each stage.</p> <p>2. In-position stability is reported as 3-sigma value (requires a 1 Vpp encoder).</p> <p>3. Payload specifications assume that the payload is centered on-axis.</p> <p>4. Specifications are for single-axis systems measured 25 mm above the tabletop; performance of multi-axis system depend upon the payload and workpoint. Consult the Aerotech factory for multi-axis or non-standard applications.</p> <p>5. -PL2 performance requires the use of an Aerotech controller.</p> <p>6. To ensure the achievement and repeatability of specifications over an extended period of time, environmental temperature must be controlled to within 0.25°C per 24 hours. Consult the Aerotech factory for more information.</p> <p>7. The air supply for the pneumatic counterbalance must be clean, dry to 0°F dewpoint, and filtered to 0.25 µm or better. Use nitrogen at 99.9% purity for best results. Supply pressure is determined by the amount of payload carried by the stage.</p>					

1.4. Air Requirements

The air supply to the counterbalance should be clean and liquid water should not be present.

- If nitrogen is used, it must be 99.99% pure and filtered to 0.25 microns. [Recommended]
- If compressed air is used, it must be filtered to 0.25 microns, dry to 0° F dew point, and oil free.

The maximum allowable input pressure specification is 0.6 MPa (87 psi).

The low friction air cylinder consumes air as described in [Figure 1-1](#).

Figure 1-1: Counterbalance Air Flow vs. Counterbalance Pressure

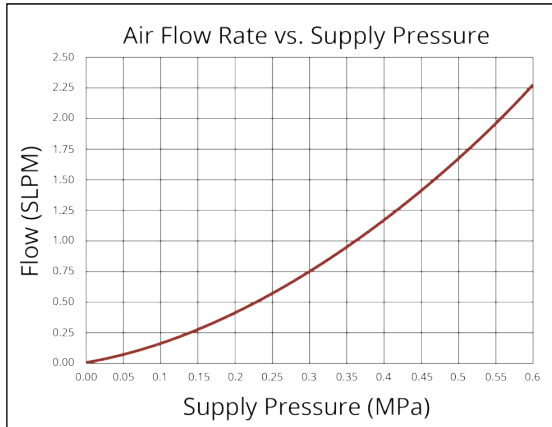
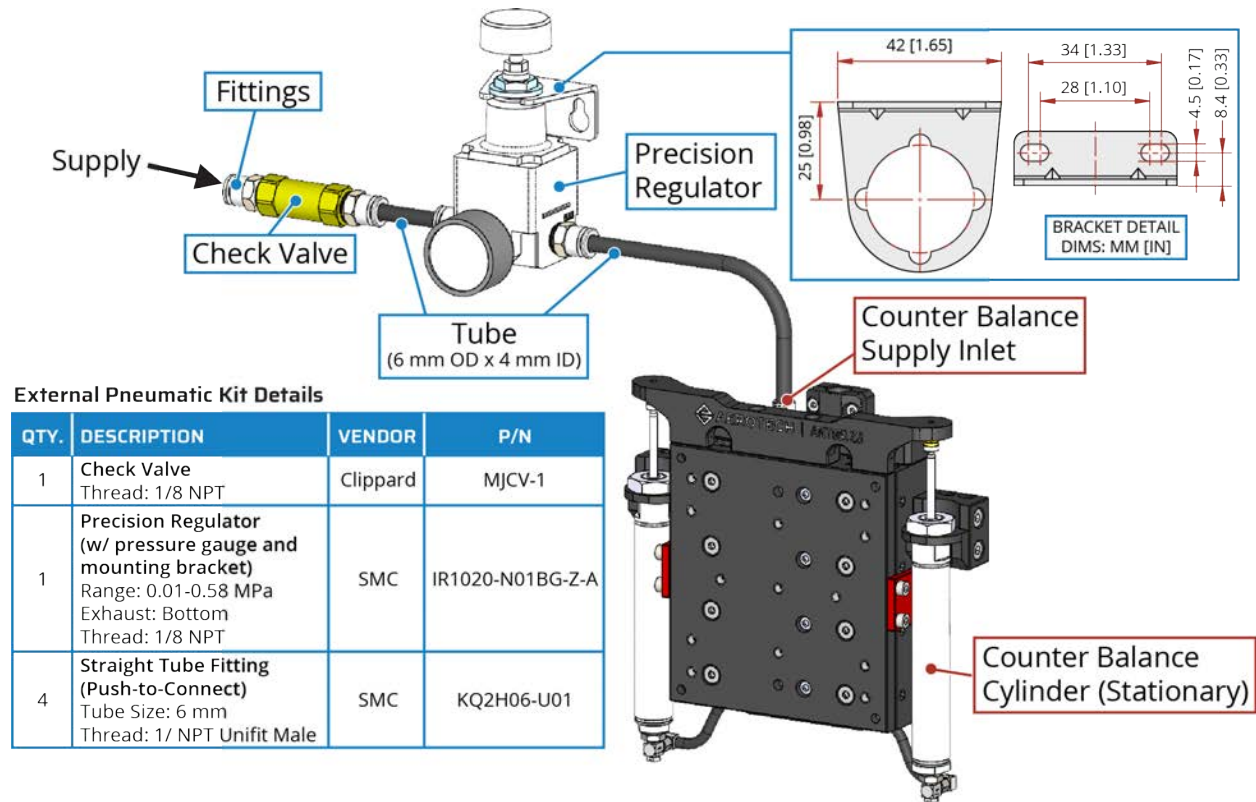

Figure 1-2: Air Inlet Location



Chapter 2: Installation



IMPORTANT: The stage installation must be in accordance with the instructions provided by this manual and any accompanying documentation. Failure to follow these instructions could result in injury or damage to the equipment.

2.1. Dimensions

Figure 2-1: ANT95LZS Dimensions

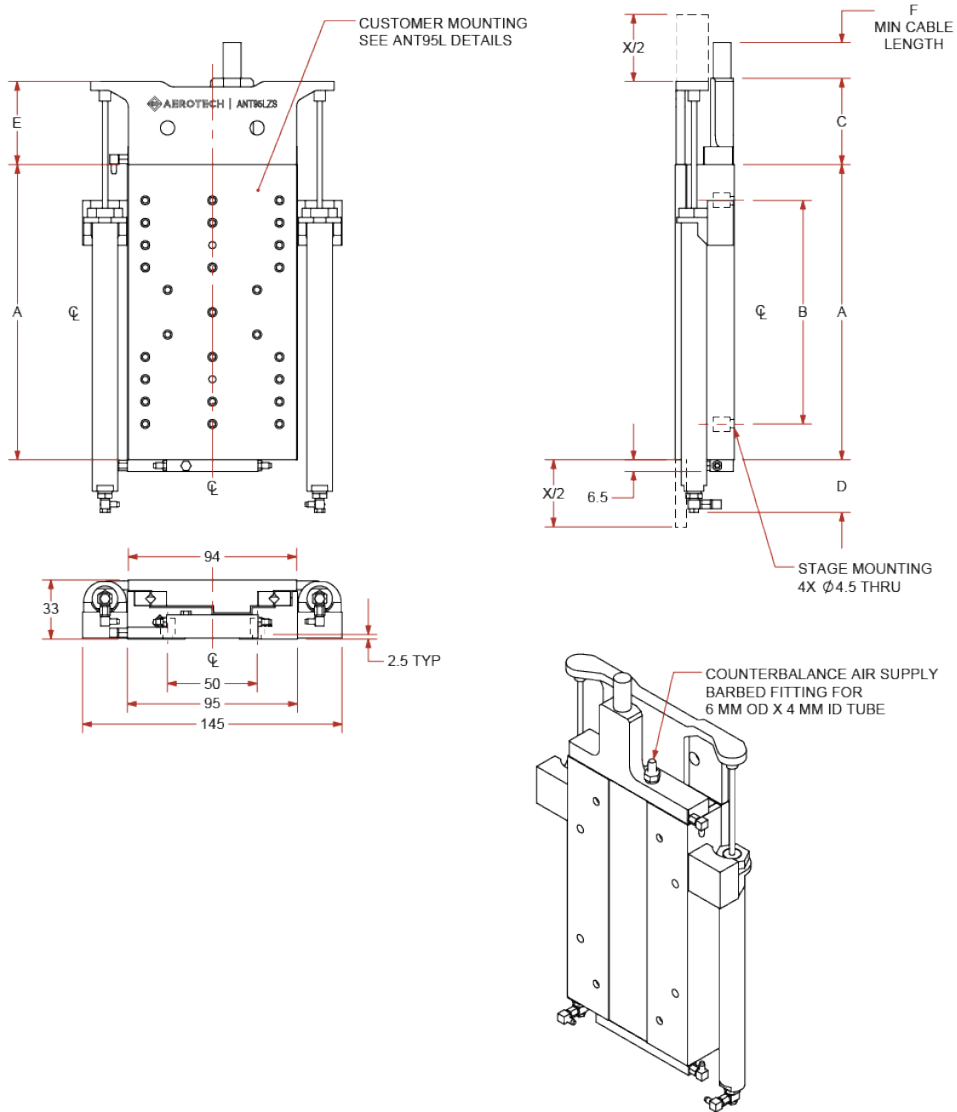

TRAVEL OPTION	A STAGE LENGTH	X NOMINAL TRAVEL	X LIMIT TRAVEL	X HARDSTOP TRAVEL	B	C	D	E	F
-025	100	25	26	28	75	23	27	20	800
-050	140	50	52	56	100	23	22	39	775
-075	165	75	77	81	125	48	30	46.5	750
-100	210	100	102	106	125	61	42	59	700

DIMENSIONS: MILLIMETERS



2.2. Securing the Stage to the Mounting Surface

DANGER: Mechanical Hazard!



Personnel must be made aware of the mechanical hazards during set up or when you do service to the stage.

- Do not manually move the stage if it is connected to a power source.
- The stage must be mounted securely. Improper mounting can result in injury and damage to the equipment.
- When you move the tabletop manually to do maintenance, this could expose the operator to internal pinch points. Refer to [Pinch Points](#) on [Page 12](#).



DANGER: Magnetic Field Hazard! When you move the tabletop manually to do maintenance, this could expose the operator to the magnet track. Refer to [Magnetic Hazards](#) on [Page 13](#).

The mounting surface must be flat and have adequate stiffness to achieve the maximum performance from the stage. When it is mounted to a non-flat surface, the stage can be distorted while the mounting screws are tightened. This distortion will decrease overall accuracy. Adjustments to the mounting surface must be done before the stage is secured.

Inspect the mounting surface for dirt or unwanted residue and clean if necessary. Use precision flatstones on the mounting surface to remove any burrs or high spots. Clean the mounting surface with a lint-free cloth and acetone or isopropyl alcohol and allow the cleaning solvent to completely dry. Gently place the stage on the mounting surface.



IMPORTANT: The stage is precision machined and verified for flatness prior to product assembly at the factory. If machining is required to achieve the desired flatness, it should be performed on the mounting surface rather than the stage. Shimming should be avoided if possible. If shimming is required, it should be minimized to retain maximum rigidity of the system.

Table 2-1: Stage Mounting Surface Flatness Requirement

Stage Travel	Flatness Requirement
All Travels	1 μ m per 50 mm

1. Remove the shipping brackets mounted to the sides of the stage with M3 screws. Retain the shipping brackets for future use.
2. With the stage laying horizontal, push the carriage to the bottom of travel such that the cylinder rods are mostly hidden in the cylinder bodies as shown in [Figure 2-2](#). Insert one M6 socket head cap screw through an access hole in the stage (refer to [Figure 2-2](#)).
3. Two Person Step: Slowly lift the stage upright, using the cylinder mounting brackets as a lifting point. Be careful to not dislodge the loose screw that you inserted in the mounting hole in Step 2. Do not lift the stage by the cylinders, carriage assembly, or cabling.
4. Two Person Step: Lift the stage to the mounting surface and line the stage up with the mounting holes. Use a wrench to engage the previously inserted mounting screw. Make sure the screw is fully engaged in the threaded hole, but do not tighten it at this time. Rotate the stage to align the second hole, insert another screw, and thread it in without fully tightening. The screw heads should be recessed in the counter-bored holes.
5. Two Person Step: Lift the carriage by hand, and hold it up to expose the bottom mounting holes. Insert the remaining mounting screws. Align the stage per your application, and then tighten the mounting screws. Refer to [Table 2-2](#) for screw torque specifications.

Tightening torque values for the mounting hardware are dependent on the properties of the surface to which the stage is being mounted. Values provided in [Table 2-2](#) are typical values and may not be accurate for your mounting surface. Refer to [Section 2.1](#) for mounting locations and dimensions.

Table 2-2: Stage to Mounting Surface Hardware

Mounting Hardware	Typical Screw Torque
M4 SHCS (stage mounting)	2.0 N·m [18 lb·in]
M5X0.8 (alternate mounting)	4.1 N·m [36 lb·in]
M6 or (1/4") SHCS ([-MP] option)	7.0 N·m [61 lb·in]

Figure 2-2: Mounting Hole Pattern

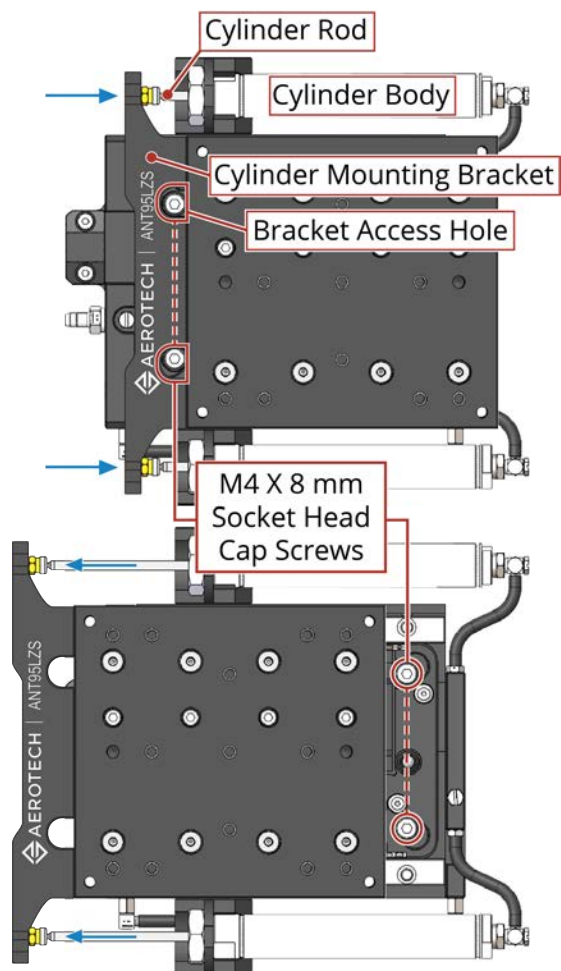

2.2.1. Setting up the Pneumatic Counterbalance



WARNING: General Hazard Warning!

- If you do not adjust counterbalance according to the instructions that follow, you can possibly injure yourself or cause damage the equipment.
- If the pneumatic counterbalance suddenly loses pressure, the carriage will quickly drop. This could cause an injury or damage the equipment.

By default, the ANT95LZS pneumatic counterbalances are factory set to operate in the as-shipped condition. For stages that are shipped unloaded, the counterbalance is set for the mass of the carriage only. For stages that ship with payloads or other axes attached, the counterbalance is set for the mass of the carriage plus the additional mass. Any adjustment to the mass that is carried by the counterbalance cylinders, either adding or subtracting payload, necessitates an adjustment to the counterbalance pressure supplied to the pneumatic cylinders.

Standard ANT95LZS stages have two counterbalance cylinders with a combined piston area of $1.354 \times 10^{-4} \text{ m}^2$, and the moving mass of a standard ANT95LZS carriage assembly is 0.5 kg (1.1 lb). An estimate of the counterbalance pressure required to support additional load is given by the following:

$$P_c = ((m_p + 0.5) * 9.81) / (1.354 \times 10^{-4}) / 1 \times 10^6 \text{ {MPa}}$$

where

P_c = Required counterbalance pressure in MPa (maximum 0.6 MPa allowed)

m_p = mass of external payload in kg.

This relationship is shown graphically in [Figure 2-3](#).

Figure 2-3: Counterbalance Pressure vs. External Payload

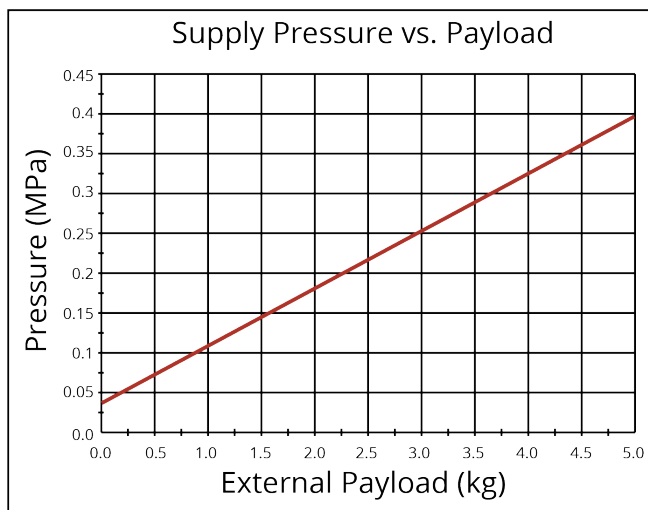

Procedure for initial pneumatic counterbalance setup:

IMPORTANT: Refer to [Section 1.4](#) for air requirements. Make sure that the air supply meets specifications before you continue.

1. Make sure that the stage is mounted and the shipping brackets are secure.
2. Loosen all shipping bracket mounting screws by one or two turns, but do not remove the screws. This will allow a small amount of travel for counterbalance setup.
3. Connect the airline to the air supply, and slowly turn on the supply pressure to the counterbalance. The pressure supply should exceed the pressure determined by [Figure 2-3](#).
 - a. The tabletop should still be hanging from the loose shipping brackets. If the tabletop starts to slowly rise, gradually lower the air supply pressure using the stage regulator knob (refer to [Figure 1-2](#)) until the carriage hangs from the shipping brackets. Counterclockwise rotation of the knob decreases the pressure to the counterbalance cylinder.
4. Slowly increase pressure to the cylinder (clockwise rotation of the regulator knob) until the carriage just starts to rise. Adjust the pressure with the regulator such that when you move the carriage to a new position by hand, the carriage neither rises nor falls.
5. The system is now balanced.
6. Remove the shipping brackets. Retain the shipping brackets for future use.
7. Proceed with the electrical installation and test the motion control system in accordance with the system documentation. For information on electrical connections, refer to [Chapter 3: Electrical Installation](#).

To turn off the air supply to the stage after the shipping brackets are removed:

1. Make sure the stage is not under servo control.
2. Gently push the carriage down to the bottom of travel until the mechanical shock engages.
3. Turn off the counterbalance pressure. Once the counterbalance pressure has completely bled out, release the hand pressure on the carriage.

To change the payload on the stage (add or remove mass), refer to [Section 2.3](#).

2.3. Attaching the Payload to the Stage

Inspect the mounting surface for dirt or unwanted residue and clean if necessary. Clean the mounting surface with a lint-free cloth and acetone or isopropyl alcohol and allow the cleaning solvent to completely dry. Gently place the stage on the mounting surface.

Use a representative payload during start-up to prevent accidental damage to the stage and the payload. Proceed with the electrical installation and test the motion control system in accordance with the system documentation. Document all results for future reference. For information on electrical installation refer to [Chapter 3: Electrical Installation](#) and the documentation delivered with the stage.



IMPORTANT: If your ANT95LZS was purchased with Aerotech controls, it could have been tuned with a representative payload based on the information provided at the time of order. If you start the ANT95LZS without a payload, the servo gains provided by Aerotech with the shipment may not be appropriate and servo instability can occur. Refer to the controller help file for tuning assistance.

The payload must be flat, rigid, and comparable to the stage in quality to maintain optimum performance.



IMPORTANT: For valid system performance, the mounting interface should be flat within 5 μm .



WARNING: General Hazard Warning!

Be careful when you attach the payload to the stage table.

- If a screw extends through the stage table, it can affect travel and damage the stage.
- Refer to the dimensions in [Section 2.1](#) for maximum allowable thread engagement.

Applied loads should be symmetrically distributed whenever possible. The payload should be centered on the stage table and the entire stage should be centered on the support structure.

Tightening torque values for the mounting hardware are dependent on the properties of the surface to which the stage is being mounted. Values provided in [Table 2-3](#) are typical values and may not be accurate for your mounting surface. Refer to [Section 2.1](#) for mounting locations and dimensions.

Table 2-3: Payload to Stage Surface Hardware

Mounting Hardware	Typical Screw Torque
M4 SHCS	2.0 N·m [18 lb·in]



IMPORTANT: If possible, use 3-point mounting when you attach the payload to the stage.

If cantilevered loads are applied, refer to [Figure 2-4](#) to find the loading condition. Refer to [Figure 2-5](#) to find the maximum allowable load.

**WARNING: General Hazard Warning!**

- Refer to the counterbalance setup instructions if the payload on the stage is changed ([Section 2.2.1.](#)).
- If the pneumatic counterbalance suddenly loses pressure, the carriage will quickly drop. This could cause an injury or damage the equipment.

**IMPORTANT:** Do not turn off air supply to system.

- You will need make adjustments to the pneumatic pressure in this procedure.
- Refer to [Section 1.4.](#) for air requirements. Make sure that the air supply meets specifications before you continue.

ANT95LZS Payload Mounting Steps:

1. Secure the ANT95LZS to the mounting surface (refer to [Section 2.2.](#)).
2. Confirm that all electrical power is disconnected before you make any mechanical adjustments.
3. Make sure that the shipping bracket is removed from the stage.
4. Adjust the air supply pressure until the tabletop reaches equilibrium.
5. With the air supply on, securely reattach the shipping bracket to the stage.
6. Attach the payload to the stage.
7. Loosen but do not remove the two M3 button head screws that secure the shipping clamp to the tabletop. This will allow the tabletop to fall a small amount.
8. Adjust the air supply pressure until the tabletop reaches equilibrium.
9. Completely remove the shipping clamp, and verify the stage is at equilibrium. Make adjustments as necessary.
10. Reconnect the electrical power.

Figure 2-4: Load Orientations

Figure 2-5: Cantilevered Load Capabilities



Chapter 3: Electrical Installation

DANGER: Electrical Shock Hazard!

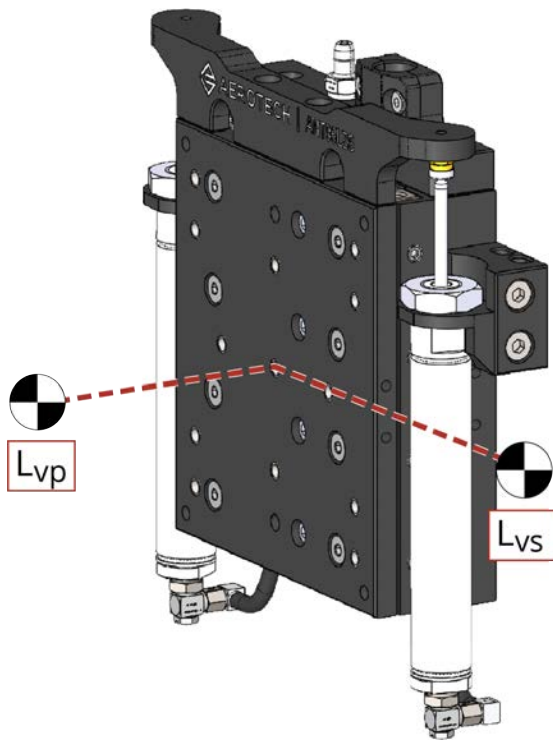
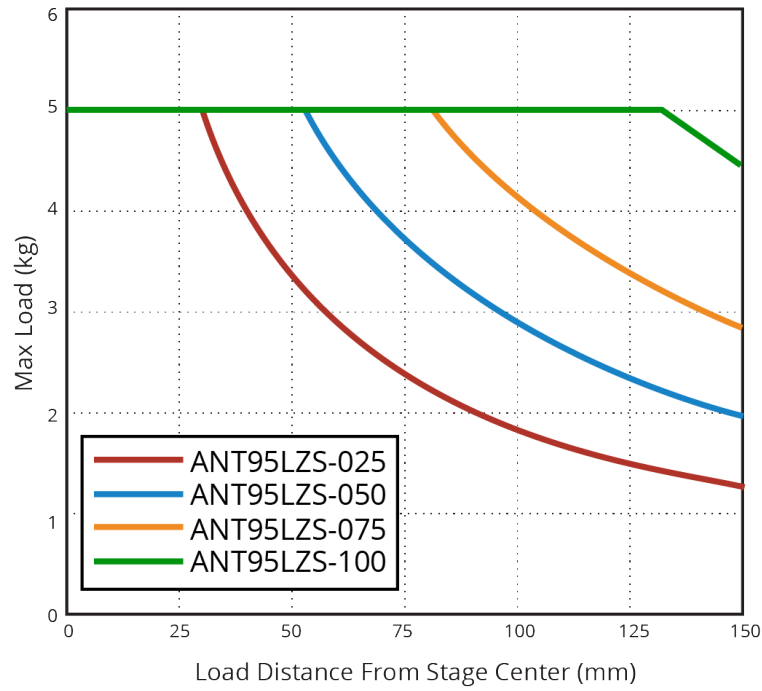

- Stage motor phase voltage levels could be hazardous live.
- Personnel are protected from hazardous voltages unless electrical interconnections, protective bonding (safety ground), or motor/stage enclosures are compromised.
- Do not connect or disconnect stage/motor interconnections while connected to a live electrical power source.
- Before you set up or do maintenance, disconnect electrical power.
- It is the responsibility of the End User/System Integrator to make sure that stages are properly connected and grounded per Engineering Standards and applicable safety requirements.
- It is the responsibility of the End User/System Integrator to configure the system drive or controller within the Aerotech motor/stage electrical and mechanical specifications.

WARNING: General Hazard Warning!



Applications that require access to the ANT95LZS must be restricted to qualified and trained personnel. The system integrator or qualified installer is responsible for determining and meeting all safety and compliance requirements when they integrate the ANT95LZS into a completed system.

Electrical installation requirements will depend on the ordered product options. Installation instructions in this section are for Aerotech products equipped with standard Aerotech motors intended for use with an Aerotech motion control system. Contact Aerotech for further information on products that are otherwise configured.

Aerotech motion control systems are adjusted at the factory for optimum performance. When the ANT95LZS is part of a complete Aerotech motion control system, setup should only require that you connect the stage to the appropriate drive chassis with the cables provided. Labels on the system components should indicate the appropriate connections.

If system level integration was purchased, an electrical drawing that shows the system interconnects has been supplied with the system (separate from this documentation).

The electrical wiring from the motor and encoder are integrated at the factory. Refer to the sections that follow for standard motor wiring and connector pinouts.



IMPORTANT: Refer to the controller documentation to adjust servo gains for optimum velocity and position stability.

3.1. Motor and Feedback Connectors

Stages equipped with standard motors and encoders come from the factory completely wired and assembled.



IMPORTANT: Refer to the other documentation accompanying your Aerotech equipment. Call your Aerotech representative if there are any questions on system configuration.



IMPORTANT: If using standard Aerotech motors and cables, motor and encoder connection adjustments are not required.

The protective ground connection of the ANT95LZS provides motor frame ground protection only. Additional grounding and safety precautions are required for applications requiring access to the stage while it is energized. The System Integrator or qualified installer is responsible for determining and meeting all safety and compliance requirements necessary for the integration of this stage into the final application.



DANGER: Electrical Shock Hazard!

- The protective ground connection must be properly installed to minimize the possibility of electric shock.
- The stage controller must provide over-current and over-speed protection. Failure to do so could cause electric shock or damage to the equipment.

Table 3-1: 25-Pin Motor and Feedback Connector Pinout

Pin	Description	Connector
Case	Shield Connection	
1	Key	
2	COS- (Encoder Cosine-)	
3	SIN- (Encoder Sine-)	
4	MRK- (Encoder Marker-)	
5	Common ground	
6	Common ground	
7	-/CCW LMT (End-of travel limit signal that indicates maximum permitted stage travel in the "machine negative" or "machine counter-clockwise" direction.)	
8	Hall Effect Sensor (Phase A)	
9	Hall Effect Sensor (Phase C)	
10	Frame Ground	
11	Motor Phase A	
12	Motor Phase B	
13	Motor Phase C	
14	COS+ (Encoder Cosine+)	
15	SIN+ (Encoder Sine+)	
16	MRK+ (Encoder Marker+)	
17	5V Power Supply Input	
18	Reserved	
19	+/CW LMT (End-of travel limit signal that indicates maximum permitted stage travel in the "machine positive" or "machine clockwise" direction.)	
20	Over-Temperature Thermistor Sensor	
21	Hall Effect Sensor (Phase B)	
22	Frame Ground and Shield Connection	
23	Motor Phase A	
24	Motor Phase B	
25	Motor Phase C	

Table 3-2: 25-Pin Mating Connector Part Numbers

Mating Connector	Aerotech P/N	Third Party P/N
25-Socket D-Connector	ECK00300	FCI DB25S064TLF
Backshell	ECK00656	Amphenol 17E-1726-2

3.2. Motor and Feedback Wiring

Shielded cables are required for the motor and feedback connections.

Figure 3-1: ANT95LZS Motor and Feedback Wiring

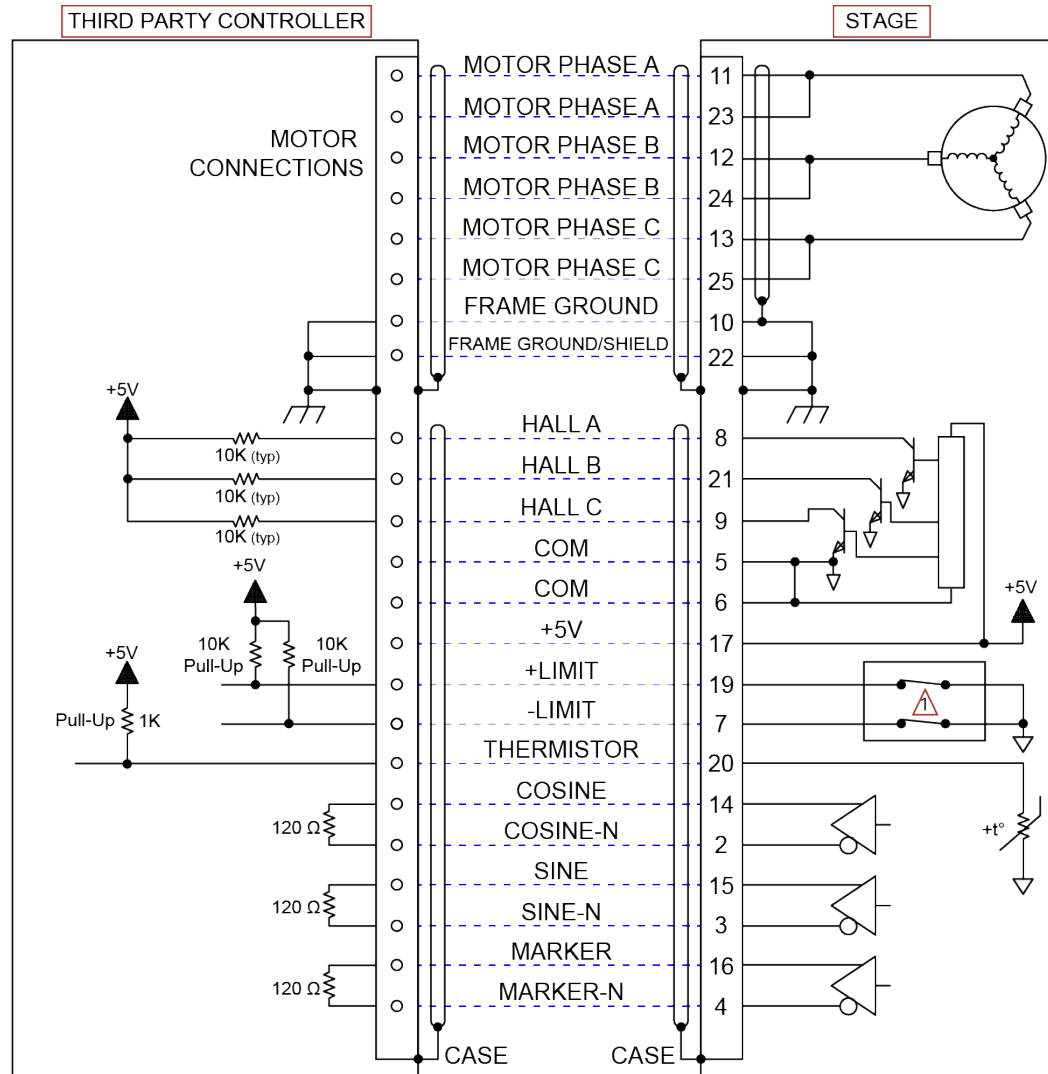

Over-travel limit switches are normally-closed.

3.3. Motor and Feedback Specifications



IMPORTANT: All 5 V supplies share one common connection within the stage.

Table 3-3: Hall-Effect Sensor Specifications

	Specification
Supply Voltage	5 V \pm 5%
Supply Current	50 mA
Output Type	Open Collector
Output Voltage	24 V max (pull up)
Output Current	5 mA (sinking)

Table 3-4: Thermistor Specifications

	Specification
Polarity	Logic "0" (no fault)
	Logic "1" (over-temperature fault)
Cold Resistance	\sim 100 Ω
Hot Resistance	\sim 10 K
Note: 1K pull-up to +5V recommended.	

Table 3-5: Encoder Specifications

	Specification
Supply Voltage	5 V \pm 5%
Supply Current	250 mA (typical)
Output Signals	Sinusoidal Type (Differential Incremental Encoder): <ul style="list-style-type: none"> Analog: SIN+, SIN-, COS+, COS-, 1V_{pk-pk} into 120Ω terminations. Digital (RS422): MRK+, MRK- signals into 120Ω terminations.
	Digital Output (Incremental Encoder): RS422/485 compatible

Table 3-6: Limit Switch Specifications

	Specification
Supply Voltage	5 V \pm 5%
Supply Current	25 mA
Output Type	Open Collector
Output Voltage	5 V
Output Current	10 mA (sinking)
Output Polarity (Factory Configured)	Normally Closed (NC) <ul style="list-style-type: none"> Sinks current to ground (Logic "0") when not in limit High impedance (Logic "1") when in limit Requires external pull-up to +5 V (10 kΩ recommended)
Note: If the ANT95LZS is driven beyond the electrical limit, it will encounter a mechanical stop. Impacting the mechanical stop could cause damage to the stage even at low speeds.	

Table 3-7: ANT95LZS Motor Specifications

		Linear Motor ANT95LZS-025	Linear Motor ANT95LZS-050	Linear Motor ANT95LZS-075	Linear Motor ANT95LZS-100
Performance Specifications^(1,5)					
Continuous Force ⁽²⁾	N (lb)	7.7 (1.73)	9.7 (2.17)	9.7 (2.17)	12.9 (2.89)
Electrical Specifications⁽⁵⁾					
Winding Designation		-A	-A	-A	-A
BEMF Constant (Line to Line, Max)	V/m/s (V/in/s)	2.86 (0.07)	3.78 (0.10)	3.78 (0.10)	4.77 (0.12)
Continuous Current ⁽²⁾	Amp _{pk} (Amp _{rms})	3.10 (2.19)	2.94 (2.08)	2.94 (2.08)	3.10 (2.19)
Peak Current, Stall ⁽³⁾	Amp _{pk} (Amp _{rms})	12.40 (8.77)	11.76 (8.31)	11.76 (8.31)	12.40 (8.77)
Force Constant, Sine Drive ^(4, 8)	N/Amp _{pk} (lb/Amp _{pk})	2.48 (0.56)	3.28 (0.74)	3.28 (0.74)	4.15 (0.93)
	N/Amp _{rms} (lb/Amp _{rms})	3.51 (0.79)	4.65 (1.05)	4.65 (1.05)	5.87 (1.32)
Motor Constant ^(2,4)	N/ \sqrt{W} (lb/ \sqrt{W})	1.21 (0.27)	1.41 (0.32)	1.41 (0.32)	1.59 (0.36)
Resistance, 25°C (Line to Line)	ohms	4.0	5.2	5.2	6.5
Inductance (Line to Line)	mH	0.51	0.70	0.70	0.87
Thermal Resistance	°C/W	2.48	2.12	2.12	1.52
Maximum Bus Voltage	VDC	80	80	80	80
Magnetic Pole Pitch	mm (in)	16.00 (0.63)	16.00 (0.63)	16.00 (0.63)	16.00 (0.63)
<p>1. Performance is dependent upon heat sink configuration, system cooling conditions, and ambient temperature.</p> <p>2. Values shown @ 100°C rise above a 25°C ambient temperature, with motor mounted to the specified aluminum heat sink.</p> <p>3. Peak force assumes correct rms current; consult Aerotech.</p> <p>4. Force constant and motor constant specified at stall</p> <p>5. All performance and electrical specifications $\pm 10\%$.</p> <p>6. Maximum winding temperature is 125°C.</p> <p>7. Ambient operating temperature range 0 °C - 25 °C; consult Aerotech for performance in elevated ambient temperatures.</p> <p>8. All Aerotech amplifiers are rated Apk; use force constant in N·m/Apk when sizing.</p>					

Table 3-8: Encoder Resolution

Encoder Option	Fundamental Signal Period	Resolution
[-E1] w/ x4000 Interpolation	20 micron	5 nm
[-E1] w/ x16000 Interpolation	20 micron	1.25 nm
[-E2]	20 micron	5 nm
[-E4] w/ x4000 Interpolation	4 micron	1 nm
[-E4] w/ x16000 Interpolation	4 micron	0.25 nm

3.4. Limits, Marker, and Machine Direction

Aerotech stages are configured to have positive and negative "machine" directions. The machine direction defines the phasing of the feedback and motor signals and is dictated by the stage wiring (refer to [Section 3.2.](#)). Programming direction of a stage is set by the controller that is used to move the stage. Programming direction is typically selectable in the controller, while machine direction is hardwired in the stage. [Figure 3-2](#) shows the machine direction of ANT95LZS stages.

Figure 3-2: Machine Direction

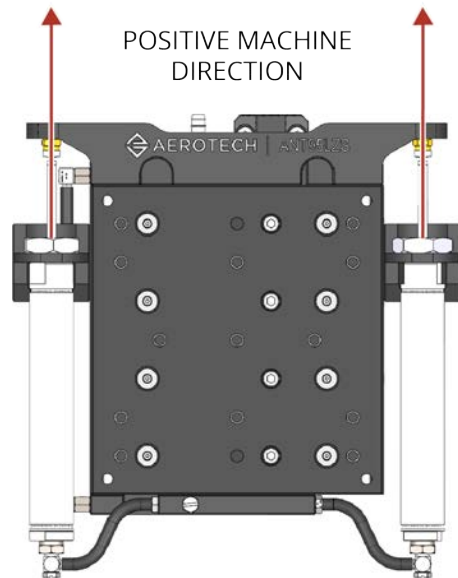

3.5. Motor and Feedback Phasing

Motor phase voltage is measured relative to the virtual wye common point.

Figure 3-3: Hall Phasing Diagram

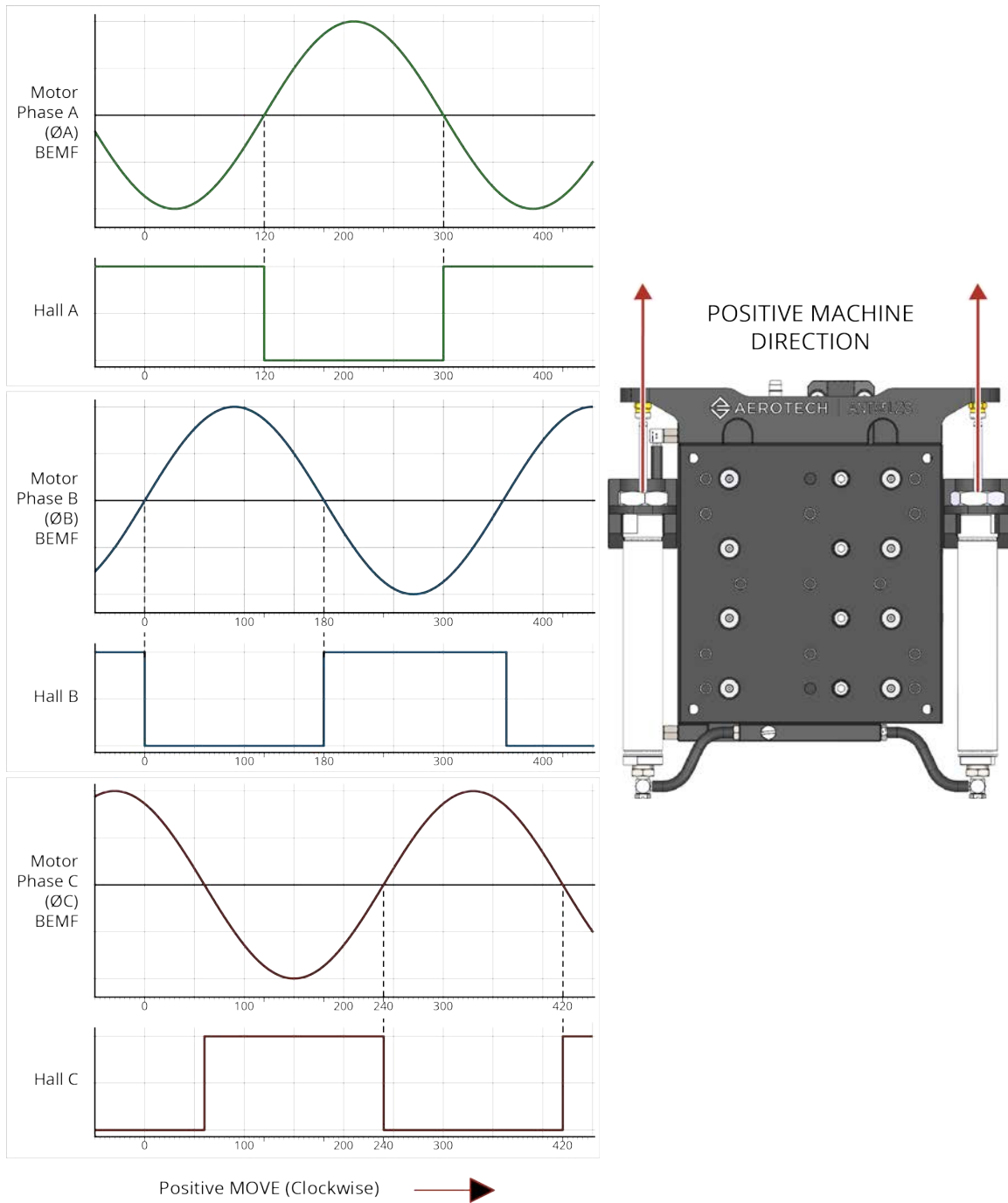

Figure 3-4: Encoder Phasing Reference Diagram (Standard/Square Wave)

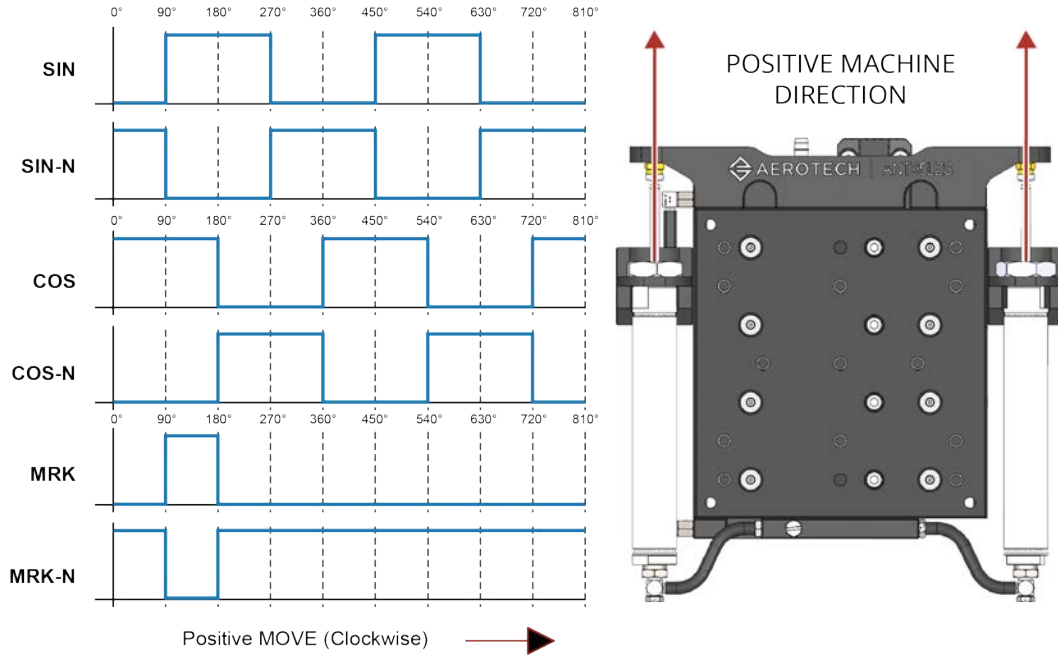
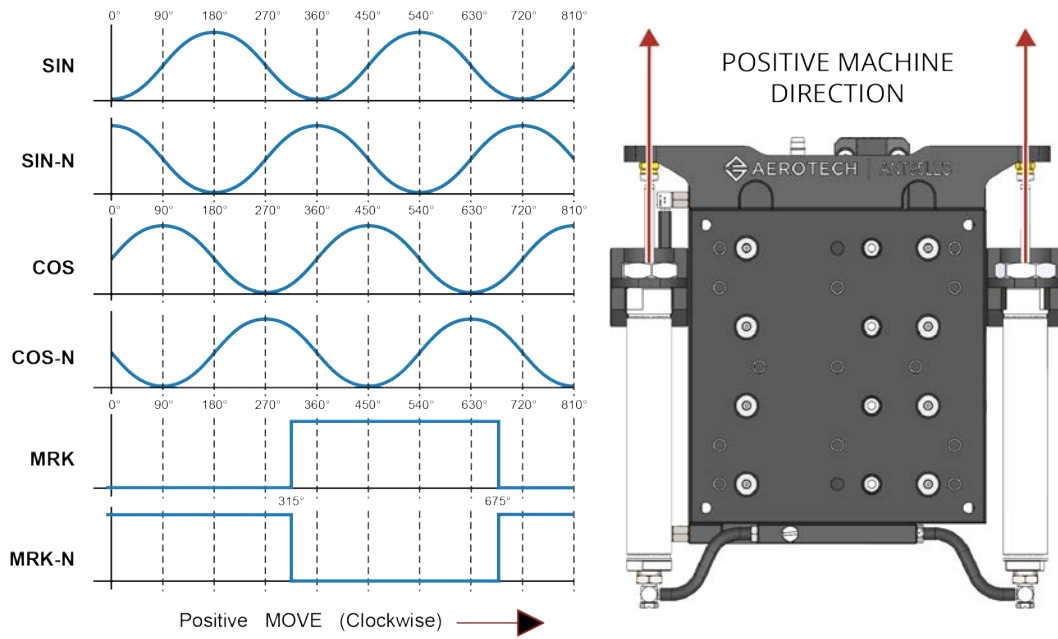

Figure 3-5: Encoder Phasing Reference Diagram (Analog/Sine Wave)



This page intentionally left blank.

Chapter 4: Maintenance



IMPORTANT: Read the [Safety Procedures and Warnings](#) (on [Page 8](#)) before you do maintenance to the stage.



IMPORTANT: Keep the bearing area free of foreign matter and moisture or the performance and life expectancy of the stage will be reduced.

4.1. Service and Inspection Schedule

Inspect the ANT95LZS at least once per month. The need for a longer or shorter inspection interval will depend on the application and conditions, such as the duty cycle, speed, and environment.

Monthly inspections should include but not be limited to:

- Visually inspect the stage and cables.
- Re-tighten loose connectors.
- Replace or repair damaged cables.
- Clean the ANT95LZS and any components and cables as needed.
- Repair any damage before operating the ANT95LZS.
- Inspect and perform an operational check on all safeguards and protective devices.

4.2. Cleaning and Lubrication



DANGER: Electrical Shock Hazard! Before you do maintenance to the equipment, disconnect the electrical power.



DANGER: Mechanical Hazard! When you move the tabletop manually to do maintenance, this could expose the operator to internal pinch points. Refer to [Pinch Points](#) on [Page 12](#).



DANGER: Magnetic Field Hazard! When you move the tabletop manually to do maintenance, this could expose the operator to the magnet track. Refer to [Magnetic Hazards](#) on [Page 13](#).



IMPORTANT: Wear appropriate personal protective equipment (PPE) when you use cleaning solvents or lubricants.

In general, if the stage operates in a clean environment, it should be cleaned and lubricated annually or every 500 km (whichever comes first). For stages that are operated under conditions with excessive debris, the stage should be cleaned every six months. For high-speed applications (those near max speed at a duty cycle of 50%), more frequent maintenance with standard lubricants will be required.

When you clean and/or lubricate components of the ANT95LZS series stage:

1. Be sure to use a clean, dry, soft, lint-free cloth for cleaning.
2. Before you use a cleaning solvent on any part of the stage, blow away small particles and dust with clean, dry, compressed air.
3. Take the opportunity during the lubrication procedure to inspect the motion guides or bearings for any damage or signs of wear.
4. In applications that have multiple stages bolted together to form multi-axis systems, the orthogonality may be lost if the stage tables of the support stages are loosened. Precision aligned stages should not be loosened or disassembled.
5. We recommend that you do not disassemble the stage beyond the instructions given in this manual. Proper assembly and calibration can only be done at the factory. Contact Aerotech for more information.

Cleaning

Use isopropyl alcohol on a lint-free cloth to clean any external metal surface of the ANT95LZS.



WARNING: General Hazard Warning! Make sure that all solvent has completely evaporated before you move the stage.

Lubrication

You should only use Kluberplex BEM 34-132 as the standard lubricant for ANT95LZS stages.

If the application process uses only a small portion of travel for most of the duty cycle, periodically drive the stage through full travel to redistribute the lubrication in the bearings.



IMPORTANT: During the lubrication procedure, inspect the linear motion guides for damage or signs of wear.



IMPORTANT: Ensure that the pneumatic counterbalance has been properly configured (refer to [Section 2.2.1.](#)).

1. Drive the stage table to one end of travel and remove power to the stage.
2. Remove any accumulated dust or debris that is visible inside of the assembly.
3. Remove any dirty or dried lubricant from the v-channels of the linear bearing rails.
 - Use a clean, lint-free cloth with a side-to-side motion.
 - Use a swab soaked in Isopropyl Alcohol to remove stubborn debris.
4. Apply a thin, continuous film of lubricant to the exposed v-channels of the cross rollers on both ends of the stage.
 - Aerotech recommends that you use a good quality, natural bristle artist's brush for the applicator.
 - Do not use any applicator that could scratch or otherwise damage the v-channels.
5. Manually move the stage to the opposite end of travel.
 - This will work the grease into the linear bearing guides.
 - The stage table should move freely with little resistance.
6. Repeat steps 2 through 4 for any areas covered by the original table position.
7. Restore power to the stage and drive the stage table back to its original position to redistribute lubricants.

4.3. Troubleshooting

Symptom	Possible Cause and Solution
Stage will not move	Shipping brackets still installed. Remove the red anodized shipping brackets. Brake not released (if equipped with brake; refer to stage documentation). In Limit condition. Check limits (refer to Chapter 3: Electrical Installation) and refer to the Controller documentation for polarity and compatibility requirements (Example: voltage requirements). Controller trap or fault (refer to the Controller documentation).
Stage moves uncontrollably	Encoder (sine and cosine) signal connections (refer to Chapter 3: Electrical Installation and Controller documentation). Motor Connections (refer to Chapter 3: Electrical Installation and the Controller documentation).
Stage oscillates or squeals	Gains misadjusted (refer to the Controller documentation). Encoder signals (refer to the Controller documentation).

Appendix A: Warranty and Field Service

Aerotech, Inc. warrants its products to be free from harmful defects caused by faulty materials or poor workmanship for a minimum period of one year from date of shipment from Aerotech. Aerotech's liability is limited to replacing, repairing or issuing credit, at its option, for any products that are returned by the original purchaser during the warranty period. Aerotech makes no warranty that its products are fit for the use or purpose to which they may be put by the buyer, whether or not such use or purpose has been disclosed to Aerotech in specifications or drawings previously or subsequently provided, or whether or not Aerotech's products are specifically designed and/or manufactured for buyer's use or purpose. Aerotech's liability on any claim for loss or damage arising out of the sale, resale, or use of any of its products shall in no event exceed the selling price of the unit.

THE EXPRESS WARRANTY SET FORTH HEREIN IS IN LIEU OF AND EXCLUDES ALL OTHER WARRANTIES, EXPRESSED OR IMPLIED, BY OPERATION OF LAW OR OTHERWISE. IN NO EVENT SHALL AEROTECH BE LIABLE FOR CONSEQUENTIAL OR SPECIAL DAMAGES.

Return Products Procedure

Claims for shipment damage (evident or concealed) must be filed with the carrier by the buyer. Aerotech must be notified within thirty (30) days of shipment of incorrect material. No product may be returned, whether in warranty or out of warranty, without first obtaining approval from Aerotech. No credit will be given nor repairs made for products returned without such approval. A "Return Materials Authorization (RMA)" number must accompany any returned product(s). The RMA number may be obtained by calling an Aerotech service center or by submitting the appropriate request available on our website (www.aerotech.com). Products must be returned, prepaid, to an Aerotech service center (no C.O.D. or Collect Freight accepted). The status of any product returned later than thirty (30) days after the issuance of a return authorization number will be subject to review.

Visit [Global Technical Support Portal](#) for the location of your nearest Aerotech Service center.

Returned Product Warranty Determination

After Aerotech's examination, warranty or out-of-warranty status will be determined. If upon Aerotech's examination a warranted defect exists, then the product(s) will be repaired at no charge and shipped, prepaid, back to the buyer. If the buyer desires an expedited method of return, the product(s) will be shipped collect. Warranty repairs do not extend the original warranty period.

Fixed Fee Repairs - Products having fixed-fee pricing will require a valid purchase order or credit card particulars before any service work can begin.

All Other Repairs - After Aerotech's evaluation, the buyer shall be notified of the repair cost. At such time the buyer must issue a valid purchase order to cover the cost of the repair and freight, or authorize the product(s) to be shipped back as is, at the buyer's expense. Failure to obtain a purchase order number or approval within thirty (30) days of notification will result in the product(s) being returned as is, at the buyer's expense.

Repair work is warranted for ninety (90) days from date of shipment. Replacement components are warranted for one year from date of shipment.

Rush Service

At times, the buyer may desire to expedite a repair. Regardless of warranty or out-of-warranty status, the buyer must issue a valid purchase order to cover the added rush service cost. Rush service is subject to Aerotech's approval.

On-site Warranty Repair

If an Aerotech product cannot be made functional by telephone assistance or by sending and having the customer install replacement parts, and cannot be returned to the Aerotech service center for repair, and if Aerotech determines the problem could be warranty-related, then the following policy applies:

Aerotech will provide an on-site Field Service Representative in a reasonable amount of time, provided that the customer issues a valid purchase order to Aerotech covering all transportation and subsistence costs. For warranty field repairs, the customer will not be charged for the cost of labor and material. If service is rendered at times other than normal work periods, then special rates apply.

If during the on-site repair it is determined the problem is not warranty related, then the terms and conditions stated in the following "On-Site Non-Warranty Repair" section apply.

On-site Non-Warranty Repair

If any Aerotech product cannot be made functional by telephone assistance or purchased replacement parts, and cannot be returned to the Aerotech service center for repair, then the following field service policy applies:

Aerotech will provide an on-site Field Service Representative in a reasonable amount of time, provided that the customer issues a valid purchase order to Aerotech covering all transportation and subsistence costs and the prevailing labor cost, including travel time, necessary to complete the repair.

Service Locations

<http://www.aerotech.com/contact-sales.aspx?mapState=showMap>

USA, CANADA, MEXICO

Aerotech, Inc.
Global Headquarters

CHINA

Aerotech China
Full-Service Subsidiary

GERMANY

Aerotech Germany
Full-Service Subsidiary

TAIWAN

Aerotech Taiwan
Full-Service Subsidiary

UNITED KINGDOM

Aerotech United Kingdom
Full-Service Subsidiary

Appendix B: Revision History

Revision	Description
2.01	Safety information updated.
2.00	New manual

This page intentionally left blank.

Thermistor Specifications	33
Troubleshooting	42
V	
Vibration	18
W	
Warnings	8
Warranty and Field Service	43