



AGV-HP(O) Two-Axis Galvo Scanner

HARDWARE MANUAL

Revision 2.00



GLOBAL TECHNICAL SUPPORT

Go to the [Global Technical Support Portal](#) for information and support about your Aerotech, Inc. products. The website supplies software, product manuals, Help files, training schedules, and PC-to-PC remote technical support. If necessary, you can complete Product Return (RMA) forms and get information about repairs and spare or replacement parts. To get help immediately, contact a service office or your sales representative. Include your customer order number in your email or have it available before you call.

This manual contains proprietary information and may not be reproduced, disclosed, or used in whole or in part without the express written permission of Aerotech, Inc. Product names mentioned herein are used for identification purposes only and may be trademarks of their respective companies.

Copyright © 2015-2021, Aerotech, Inc., All rights reserved.



Table of Contents

AGV-HP(O) Two-Axis Galvo Scanner	1
Table of Contents	3
List of Figures	4
List of Tables	5
Safety Procedures and Warnings	7
Laser Safety	9
Classes of Lasers	9
Laser Area	10
Laser Shutter	11
EU Declaration of Incorporation	13
Chapter 1: Overview	15
1.1. Environmental Specifications	20
1.2. Accuracy and Temperature Effects	20
1.2.1. Power-On Thermal Drift	20
1.3. Basic Specifications	21
1.4. Vacuum Operation	23
Chapter 2: Mechanical Specifications and Installation	25
2.1. Unpacking and Handling the Scan Head	26
2.2. Dimensions	27
2.3. Securing the Scan Head to the Mounting Surface	41
2.4. Attaching the Focal Lens to the Scan Head	43
2.5. Air Requirements	45
2.6. Water Requirements	46
Chapter 3: Electrical Specifications and Installation	47
3.1. Motor and Feedback Connectors	48
3.2. Motor and Feedback Wiring	50
3.3. Motor and Feedback Specifications	52
3.4. Limits, Marker, and Machine Direction	53
3.5. Feedback Phasing	55
Chapter 4: Maintenance	57
4.1. Service and Inspection Schedule	57
4.2. Cleaning and Lubrication	57
4.2.1. Focal Lens and Protective Glass	58
4.2.2. Turning Mirrors	59
4.3. Troubleshooting	60
Appendix A: Warranty and Field Service	61
Appendix B: Revision History	63
Index	65

List of Figures

Figure 1-1: Functional Principle of a 2-Axis Galvanometer Scanner	15
Figure 1-2: Standard AGV-HP	16
Figure 1-3: Standard AGV-HPO	16
Figure 2-1: AGV10HP-BE1 Galvanometer Scanner Dimensions	27
Figure 2-2: AGV10HP-BE2 Galvanometer Scanner Dimensions	28
Figure 2-3: AGV10HPO-BE1 Galvanometer Scanner Dimensions	29
Figure 2-4: AGV10HPO-BE2 Galvanometer Scanner Dimensions	30
Figure 2-5: AGV14HP-BE1 Galvanometer Scanner Dimensions	31
Figure 2-6: AGV14HP-BE2 Galvanometer Scanner Dimensions	32
Figure 2-7: AGV14HPO-BE1 Galvanometer Scanner Dimensions	33
Figure 2-8: AGV14HPO-BE2 Galvanometer Scanner Dimensions	34
Figure 2-9: AGV20HP-BE1 Galvanometer Scanner Dimensions	35
Figure 2-10: AGV20HP-BE2 Galvanometer Scanner Dimensions	36
Figure 2-11: AGV20HPO-BE1 Galvanometer Scanner Dimensions	37
Figure 2-12: AGV20HPO-BE2 Galvanometer Scanner Dimensions	38
Figure 2-13: AGV30HP-BE1 Galvanometer Scanner Dimensions	39
Figure 2-14: AGV30HPO-BE1 Galvanometer Scanner Dimensions	40
Figure 2-15: Example of F-Theta Lens (Complete Assembly)	43
Figure 2-16: Assembly of Focal Lens to Scan Head (AGV-HP(O))	44
Figure 2-17: Air-Cooling (-AC) Locations	45
Figure 2-18: Water Cooling (-WC) Locations	46
Figure 3-1: Motor and Feedback Wiring	51
Figure 3-2: -BE1 Galvo X-Axis Machine Direction (front)	53
Figure 3-3: -BE1 Galvo Y-Axis Machine Direction (side)	53
Figure 3-4: -BE2 Galvo X-Axis Machine Direction (front)	54
Figure 3-5: -BE2 Galvo Y-Axis Machine Direction (side)	54
Figure 3-6: Analog Encoder Phasing Reference Diagram	55

List of Tables

Table 1-1: Ordering Options	17
Table 1-2: F-Theta Lens Options(1,2,3,4)	18
Table 1-3: Environmental Specifications	20
Table 1-4: AGV-HP(O) Series Specifications	21
Table 1-5: AGV-HP(O) Series Mirror Specifications	22
Table 3-1: Motor and Feedback Connector Pinouts	49
Table 3-2: Mating Connector Part Numbers for the Motor and Feedback Connector	49
Table 3-3: Aerotech Motor and Feedback Cable Part Numbers	50
Table 3-4: Wire Gauge and Insulation Specifications	50
Table 3-5: Motor and Feedback Specifications	52
Table 4-1: Troubleshooting	60

This page intentionally left blank.

Safety Procedures and Warnings

IMPORTANT: This manual tells you how to carefully and correctly use and operate the AGV-HP(O).



- Read all parts of this manual before you install or operate the galvo or before you do maintenance to your system.
- To prevent injury to you and damage to the equipment, obey the precautions in this manual.
- All specifications and illustrations are for reference only and were complete and accurate as of the release of this manual. To find the newest information about this product, refer to www.aerotech.com.

If you do not understand the information in this manual, contact Aerotech Global Technical Support.

IMPORTANT: This product has been designed for light industrial manufacturing or laboratory environments. If the product is used in a manner not specified by the manufacturer:



- The protection provided by the equipment could be impaired.
- The life expectancy of the product could be decreased.

Safety notes and symbols are placed throughout this manual to warn you of the potential risks at the moment of the safety note or if you fail to obey the safety note.



The voltage can cause shock, burn, or death.



You are at risk of physical injury.
You could damage the galvo.



A surface can be hot enough to burn you.



Your actions, the temperature of the system, or the condition of the atmosphere that surround the system could start a fire.



You are at risk of physical injury because of exposure to lasers.



You are at risk of physical injury because of exposure to high pressure in the system.



Unsecured cables could cause you to:

- trip and fall
- drag the product off of its mounting location
- damage the cable connections.



A blue circle symbol is an action or tip that you should obey. Some examples include:



- General tip
- Read the manual/section
- Wear protective safety equipment (eye protection, ear protection, gloves)



DANGER: To decrease the risk of electrical shock, injury, death, and damage to the equipment, obey the precautions that follow.

- Electrical installation must be done by qualified personnel.
- Before you do maintenance to the equipment, disconnect the electrical power.
- Before you connect wires to this product, disconnect the electrical power.
- Do not connect or disconnect electrical components, wires, and cables while this product is connected to a power source.
- Restrict access to the galvo when it is connected to a power source.
- Make sure that all components are grounded correctly and that they obey the local electrical safety requirements.
- Supply each operator with the necessary protection from live electrical circuits.
- Install the necessary precautions to supply safety and protection to the operator.
- It is the responsibility of the system integrator or qualified installer to determine and meet all safety and compliance requirements when they integrate the AGV-HP(O) into a completed system.



IMPORTANT: The protective ground connection of the AGV-HP(O) provides motor frame ground protection only. Additional ground and safety precautions are required for applications that require access to the AGV-HP(O) while it is energized.



DANGER: Use of this product increases the risk of exposure to visible and/or invisible laser radiation.

- Do not stare into the laser beam, put your body parts in the laser area, or expose yourself to reflections from powerful beams.
- Wear certified laser safety eye protection.
- Avoid eye or skin exposure to direct or scattered radiation.



DANGER: High pressure air can cause severe injury.

- Lock out the source and bleed off the pressure before you do service to the equipment.
- Wear eye protection.
- Wear ear protection.



WARNING: To prevent damage to the equipment and decrease the risk of electrical shock and injury, obey the precautions that follow.

- Only trained operators should operate this equipment.
- Use this product only in environments and operating conditions that are approved in this manual.
- Make sure that the product is securely mounted before you operate it.
- All service and maintenance must be done by approved personnel.
- Keep the scan head free of foreign matter and moisture to prevent a reduction in its performance and life expectancy.



WARNING: Securely mount and position all system cables.



IMPORTANT: Carefully lift, move, and transport this product.



IMPORTANT: Fingerprints contain aggressive substances that can damage optical surfaces. Wear clean, powder-free gloves when you handle optical components.

Laser Safety

It is the responsibility of the user to provide the necessary conditions for safe operation of a laser system and to safeguard the work area against the dangers that can be caused by laser radiation. The user must ensure compliance with all local and national regulations.

Although the scan head by itself does not emit laser radiation, the user must undertake a thorough analysis of system safety before they operate the AGV-HP(O) in conjunction with a laser source. Important information for performing this analysis is presented in this manual. Look for additional information in the corresponding documentation supplied by the manufacturer(s) of the laser source and other system components.

Classes of Lasers

The AGV-HP(O) series scan head can be used with a variety of lasers. Each laser is assigned a particular hazard level, which is indicated by the Laser Class label that is affixed to the device near the location where laser radiation is emitted. Brief descriptions of each of the various radiation classes are presented in the table below.

Note that in addition to the dangers of radiation, lasers can pose further dangers, such as the risk of electrical shock or the generation of poisonous fumes.

Classifications of Laser Devices

	Class	Danger
	Class I	Inherently safe; no possibility of eye damage during normal operation.
	Class IIa	Requires in excess of 1000 seconds of continuous viewing to cause eye damage.
	Class II	The blink reflex will prevent eye damage, unless the person deliberately stares into the beam for an extended period of time.
	Class IIIa	Mostly dangerous in combination with optical instruments which change the beam diameter or power density. However, even without optical enhancement, direct contact for over two minutes could cause eye damage.
	Class IIIb	Direct exposures of 0.01 second or less could cause eye and skin damage.
	Class IV	Direct or scattered radiation without optical enhancement could cause eye and skin damage.

Laser Area

The area in which the maximum permitted radiation value can be exceeded is defined as the laser area. In general, a laser area is applicable to Class IIIa, IIIb and IV laser systems. A laser area can also be produced if you focus the beam of a Class I, IIa, or II laser device.

The AGV-HP(O) can aim the laser beam over an approximately pyramidal volume. When the scan head is used in conjunction with a laser device that can generate a sufficiently intense beam, a laser area will be produced that includes the aiming volume as well as the reflections from all objects that can be exposed to the radiation. It is important to note that even apparently diffuse surfaces can reflect laser radiation and a laser beam that has been reflected several times can still be dangerous.

The laser area must be designated by suitable warning signs or lamps and protected by appropriate shading and interlock switches.

Figure 1: Laser Area of an AGV-HP(O) Scan Head

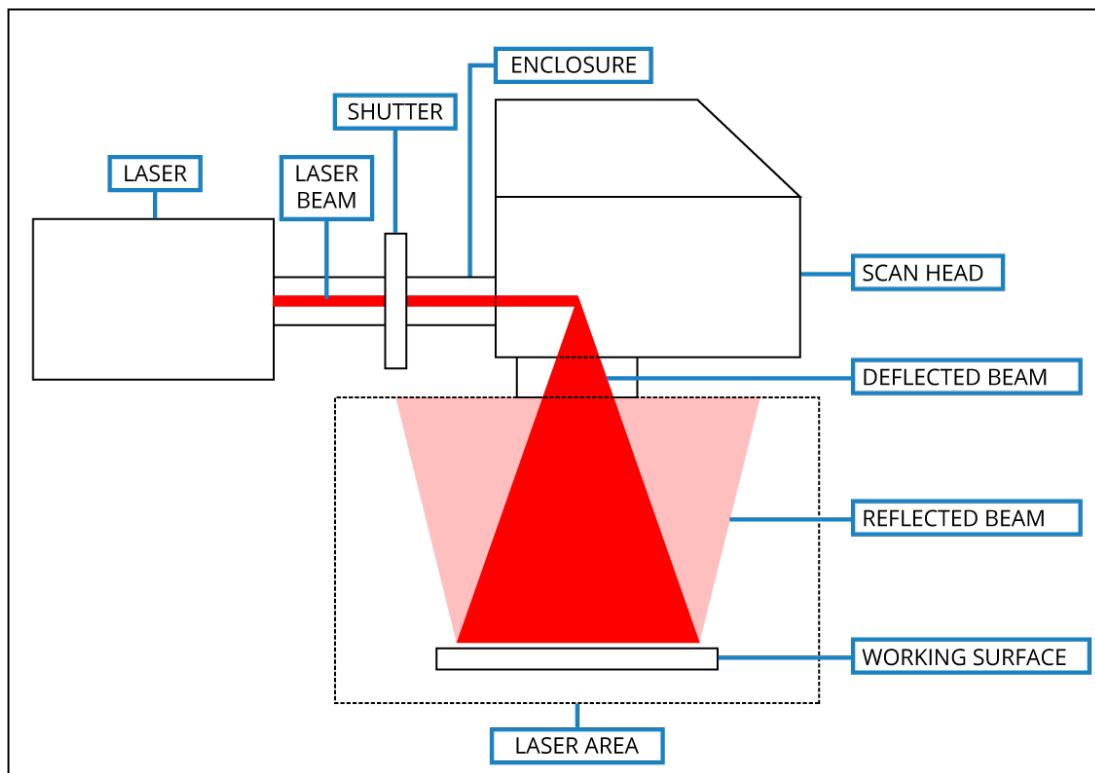

Laser Shutter

A laser attenuator (beam shutter) is a mechanical or electrical device that blocks the emission of laser radiation. It is a requirement for most classes of laser systems. The attenuator must be available for use at all times when the laser system is operated. Power switches and key controls do not satisfy the attenuator requirement.

The AGV-HP(O) scan head does not include a laser attenuator, and therefore it cannot block or weaken the laser beam. Due to the unique properties of each laser, it is the responsibility of the user to incorporate an appropriate shutter as per any and all applicable regulations in order to prevent unwanted emission of the laser beam.

Place the beam shutter between the laser source and the scan head (refer to [Figure 1](#)).



DANGER: The danger to your eyes increases when optical instruments are used in conjunction with the scan head.



- Wear certified laser safety eye protection.
- Do not stare into the laser beam, put your body parts in the laser area, or expose yourself to reflections from powerful beams.



WARNING: Aerotech recommends that you only use a Class 1 HeNe laser to do alignments. If a Class 1 HeNe laser is not available, use the lowest power setting on the available laser and remote beam sensing techniques.

This page intentionally left blank.

EU Declaration of Incorporation

Manufacturer: Aerotech, Inc.
101 Zeta Drive
Pittsburgh, PA 15238-2811
USA

herewith declares that the product:

AGV-HP(O) Scan Head

is intended to be incorporated into machinery to constitute machinery covered by the Directive 2006/42/EC as amended;

and that the following harmonized European standards have been applied:

EN ISO 12100:2010

Safety of machinery - Basic concepts, general principles for design

EN 60204-1:2010

Safety of machinery - Electrical equipment of machines - Part 1: General requirements

and further more declares that

it is not allowed to put the equipment into service until the machinery into which it is to be incorporated or of which it is to be a component has been found and declared to be in conformity with the provisions of the Directive 2006/42/EC and with national implementing legislation, for example, as a whole, including the equipment referred to in this Declaration.

This is to certify that the aforementioned product is in accordance with the applicable requirements of the following directive(s):

2011/65/EU
EU 2015/863

RoHS 2 Directive
Amendment RoHS 3 Directive

**Authorized
Representative**



/ Simon Smith, European Director

Aerotech Ltd
The Old Brick Kiln, Ramsdell, Tadley
Hampshire RG26 5PR
UK

**Engineer Verifying
Compliance**



/ Alex Weibel

Aerotech, Inc.
101 Zeta Drive
Pittsburgh, PA 15238-2811
USA
12/15/2021

Date



This page intentionally left blank.

Chapter 1: Overview

A 2-axis galvanometer scanner is used to deflect a laser beam in the X and Y directions. The laser can be directed to any position within the two-dimensional area, which is called the “marking field”. Deflection of the laser beam is accomplished by two mirrors, each of which is actuated by a galvanometer. Every scan head includes a beam entrance aperture, into which the laser beam is fed, and a beam exit aperture, through which the laser beam is emitted from the unit after deflection. Only suitable lasers of the appropriate wavelength, power level, beam diameter, etc., may be fed into the beam entrance aperture. Contact the factory for mirror and coating details. Depending on the options selected for the particular scan head, the beam exit aperture may be either open or fitted with a focal lens.

Figure 1-1: Functional Principle of a 2-Axis Galvanometer Scanner

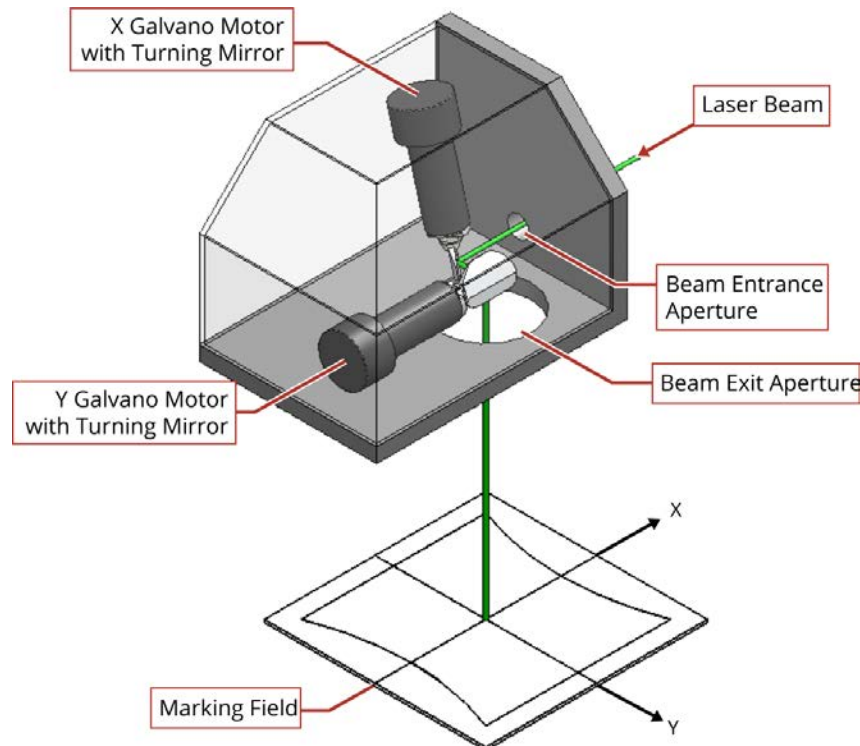

The AGV-HP(O) control connections are two 25-pin D-style connectors. The scanner cables can be oriented in any direction and terminated on the machine to ensure there is no interference with beam delivery. The AGV-HPO is also available with right-side and left-side input apertures for “mirror image” machine builds or side-by-side scanner mounting with a single laser beam split to source both scanners.

Figure 1-2: Standard AGV-HP

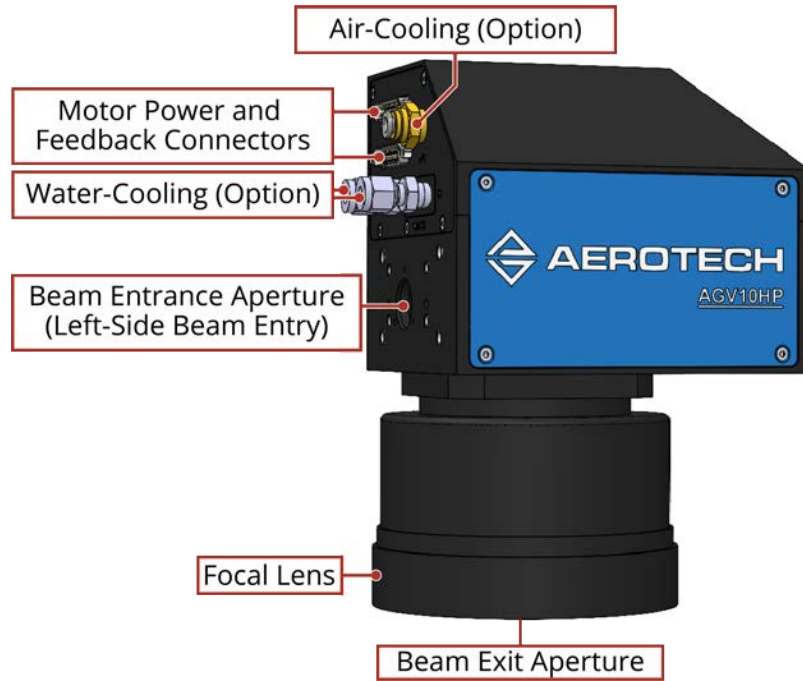

Figure 1-3: Standard AGV-HPO

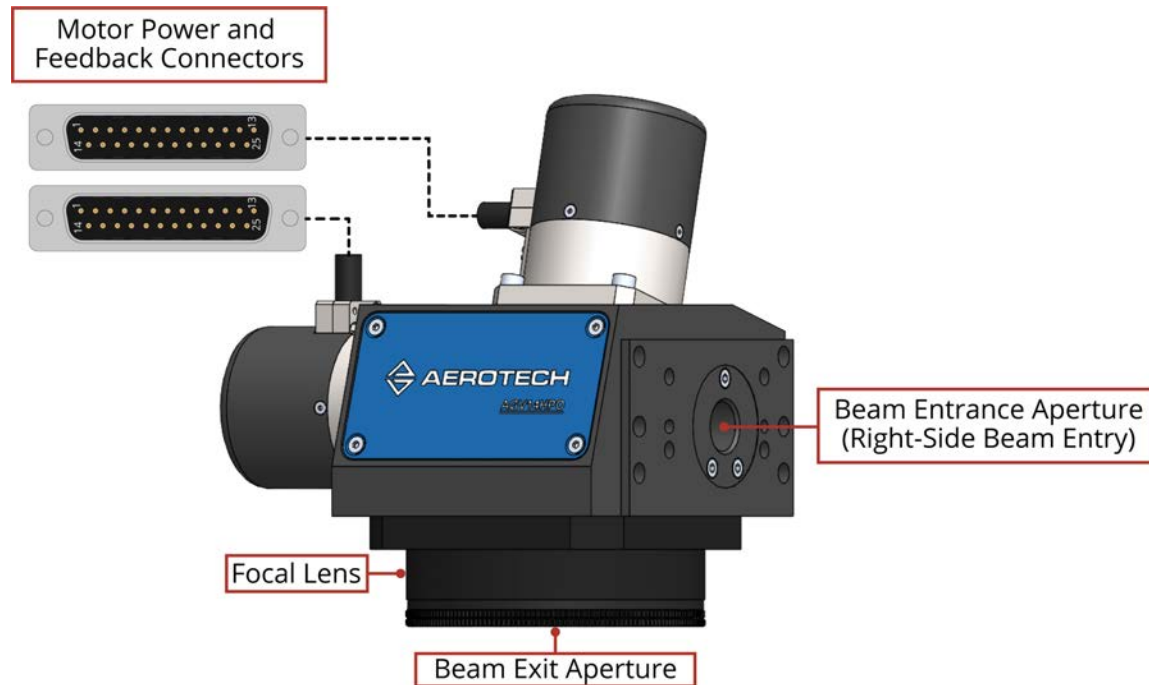

Table 1-1: Ordering Options

AGV-HP(O) Series High Performance Galvanometer Scanner				
AGV10HP	2-axis galvanometer scanner with 10 mm diameter beam aperture and integral high-precision feedback			
AGV14HP	2-axis galvanometer scanner with 14 mm diameter beam aperture and integral high-precision feedback			
AGV20HP	2-axis galvanometer scanner with 20 mm diameter beam aperture and integral high-precision feedback			
AGV30HP	2-axis galvanometer scanner with 30 mm diameter beam aperture and integral high-precision feedback			
Housing Type (Required)				
-	Closed scanner housing (AGVxxHP)			
O	Open scanner housing (AGVxxHPO)			
Beam Entry Orientation (Required)				
	AGV10HP(O)	AGV14HP(O)	AGV20HP(O)	AGV30HP(O)
-BE1	Right-side (standard)	Right-side (standard)	Right-side (standard)	Right-side (standard)
-BE2	Left-side	Left-side	Left-side	N/A
Wavelength of Mirror Coating⁽¹⁾ (Required)				
	AGV10HP(O)	AGV14HP(O)	AGV20HP(O)	AGV30HP(O)
-W001	10.6 μm			
-W002	Durable Silver (450 nm-10.6 μm)			
-W003	1552 nm			
-W004	1064 nm			
-W005	1030 nm			
-W006	532 nm			
-W007	515 nm			
-W008	355 nm			
-W009	343 nm			
-W012	9.3 μm			
NOTE: Custom coatings available. Contact factory for details.				
F-Theta Lenses Available (Optional)				
-Lxx	See Table 1-2 for standard F-Theta Lens options			
Mounting Plate (Optional)				
-MP	Mounting plate			
Air Cooling (Optional, refer to Section 2.5.)				
-AC	Air cooling			
Water Cooling (Optional, refer to Section 2.6.)				
-WC	Water cooling			

Table 1-2: F-Theta Lens Options^(1,2,3,4)

		AGV10HP(O)	AGV14HP(O)	AGV20HP(O)	AGV30HP(O)
-L1	Wavelength	1552 nm	--	10.6 μm	10.6 μm
	Focal Length	100 mm	--	100 mm	255 mm
	Design	Telecentric	--	Telecentric	--
-L2	Wavelength	1552 nm	--	10.6 μm	1064 nm
	Focal Length	163 mm	--	160 mm	200 mm
	Design	Telecentric	--	--	--
-L3	Wavelength	1064 nm	1552 nm	10.6 μm	1064 nm
	Focal Length	100 mm	100 mm	255 mm	255 mm
	Design	Telecentric	Telecentric	--	--
-L4	Wavelength	1064 nm	1552 nm	1064 nm	1064 nm
	Focal Length	100 mm	163 mm	100 mm	500 mm
	Design	Telecentric	Telecentric	Telecentric	--
-L5	Wavelength	1064 nm	1064 nm	1064 nm	--
	Focal Length	160 mm	100 mm	163 mm	--
	Design	--	--	--	--
-L6	Wavelength	1064 nm	1064 nm	1064 nm	--
	Focal Length	163 mm	100 mm	163 mm	--
	Design	Telecentric	Telecentric	Telecentric	--
-L7	Wavelength	1030 nm	1064 nm	1064 nm	--
	Focal Length	100 mm	160 mm	255 mm	--
	Design	Telecentric	--	--	--
-L8	Wavelength	1030 nm	1064 nm	532 nm	--
	Focal Length	163 mm	163 mm	255 mm	--
	Design	Telecentric	Telecentric	--	--
-L9	Wavelength	532 nm	1064 nm	--	--
	Focal Length	100 mm	170 mm	--	--
	Design	--	--	--	--
-L10	Wavelength	532 nm	1030 nm	--	--
	Focal Length	100 mm	100 mm	--	--
	Design	Telecentric	Telecentric	--	--
-L11	Wavelength	532 nm	1030 nm	--	--
	Focal Length	160 mm	163 mm	--	--
	Design	--	Telecentric	--	--
-L12	Wavelength	532 nm	532 nm	--	--
	Focal Length	163 mm	100 mm	--	--
	Design	Telecentric	Telecentric	--	--
-L13	Wavelength	515 nm	532 nm	--	--
	Focal Length	100 mm	160 mm	--	--
	Design	Telecentric	--	--	--

(1) Input beam diameter is assumed to be equal to scan head entrance aperture at $1/e^2$ Gaussian profile.

(2) Reported field-of-view (FOV) sizes are approximate and could be subject to minor variation as a function of the application laser and optical parameters. Contact the factory for details.

(3) Custom lenses are available. Contact the factory for details.

(4) Some F-theta lenses are not recommended for use with short-pulse lasers (picosecond and femtosecond pulse durations). Contact factory for alternate lens options that are compatible with short-pulse lasers.

F-Theta Lens Options (Continued)^(1,2,3,4)

		AGV10HP(O)	AGV14HP(O)	AGV20HP(O)	AGV30HP(O)
-L14	Wavelength	515 nm	532 nm	--	--
	Focal Length	163 mm	163 mm	--	--
	Design	Telecentric	Telecentric	--	--
-L15	Wavelength	355 nm	532 nm	--	--
	Focal Length	53 mm	170 mm	--	--
	Design	Telecentric	--	--	--
-L16	Wavelength	355 nm	515 nm	--	--
	Focal Length	100 mm	100 mm	--	--
	Design	Telecentric	Telecentric	--	--
-L17	Wavelength	355 nm	515 nm	--	--
	Focal Length	160 mm	163 mm	--	--
	Design	--	Telecentric	--	--
-L18	Wavelength	355 nm	355 nm	--	--
	Focal Length	163 mm	53 mm	--	--
	Design	Telecentric	Telecentric	--	--
-L19	Wavelength	355 nm	355 nm	--	--
	Focal Length	255 mm	163 mm	--	--
	Design	--	Telecentric	--	--
-L20	Wavelength	--	355 nm	--	--
	Focal Length	--	255 mm	--	--
	Design	--	--	--	--
-L21	Wavelength	--	343 nm	--	--
	Focal Length	--	53 mm	--	--
	Design	--	Telecentric	--	--
-L22	Wavelength	--	343 nm	--	--
	Focal Length	--	163 mm	--	--
	Design	--	Telecentric	--	--
-L23	Wavelength	--	343 nm	--	--
	Focal Length	--	255 mm	--	--
	Design	--	--	--	--

(1) Input beam diameter is assumed to be equal to scan head entrance aperture at 1/e² Gaussian profile.
(2) Reported field-of-view (FOV) sizes are approximate and could be subject to minor variation as a function of the application laser and optical parameters. Contact the factory for details.
(3) Custom lenses are available. Contact the factory for details.
(4) Some F-theta lenses are not recommended for use with short-pulse lasers (picosecond and femtosecond pulse durations). Contact factory for alternate lens options that are compatible with short-pulse lasers.

1.1. Environmental Specifications



WARNING: Use this product only in environments and operating conditions that are approved in this manual.

Table 1-3: Environmental Specifications

Ambient Temperature	The optimal operating temperature is 20° C ±2° C (68° F ±4° F). If at any time the operating temperature deviates from 20° C degradation in performance could occur.
	Storage: 0° to 40° C (32° to 104° F) in original shipping packaging
Humidity	Operating: 20% to 60% RH
	Storage: 10% to 70% RH, non-condensing in original packaging. The stage should be packaged with desiccant if it is to be stored for an extended time.
Altitude	Operating: 0 m to 2,000 m (0 ft to 6,562 ft) above sea level Contact Aerotech if your specific application involves use above 2,000 m or below sea level.
Vibration	Use the system in a low vibration environment. Excessive floor or acoustical vibration can affect system performance. Contact Aerotech for information regarding your specific application.
Protection Rating	The AGV-HP(O) has some protection from contamination due to laser marking and cutting processes. However, the scan head is not sealed. Dust and fumes generated by the laser machining process should be removed via an adequate exhaust or vacuum system. Failure to control this debris could result in damage to the scan head and the focal lens.
Use	Indoor use only

1.2. Accuracy and Temperature Effects

Aerotech products are designed for and built in a 20°C (68°F) environment. Extreme temperature changes could cause a decrease in performance or permanent damage to the AGV-HP(O). At a minimum, the environmental temperature must be controlled to within 0.25°C per 24 hours to ensure the AGV-HP(O) specifications are repeatable over an extended period of time. The severity of temperature effects on all specifications depends on many different environmental conditions, including how the AGV-HP(O) is mounted. Contact the factory for more details.

1.2.1. Power-On Thermal Drift

For the best possible accuracy and repeatability, it is recommended that the +5 V feedback power supply be connected to the galvano motors for a minimum of four hours prior to performing any critical operations with the AGV-HP(O). Application of the feedback power supply can raise the temperature of the galvano motors, resulting in a transient period of "power-on" thermal drift. Allowance for this warm-up period provides the galvano motors sufficient time to achieve thermal equilibrium.

In applications where a mark-and-measure calibration is performed to improve accuracy, it is essential that the calibration procedure not be conducted prior to completion of the warm-up period. Otherwise, the calibration may not be effective due to the change in zero offset that can result from the "power-on" thermal drift.

To minimize delays in operating the AGV-HP(O), it is recommended that the +5 V feedback power supply is continuously maintained to the galvano motors, even when they are not under servo control.

1.3. Basic Specifications

Table 1-4: AGV-HP(O) Series Specifications

		AGV10HP(O)	AGV14HP(O)	AGV20HP(O)	AGV30HP(O)
Optical Performance⁽¹⁾					
Beam Aperture		10 mm	14 mm	20 mm	30 mm
Maximum Scan Angle		±20°			
Beam Displacement		12.6 mm	16.5 mm	23.2 mm	35.7 mm
Feedback Resolution		0.012 μrad (25 bit)			
Dither ⁽²⁾ (Minimum Incremental Motion)		< 0.4 μrad _{RMS}			
Accuracy		50 μrad pk-pk			
Repeatability ⁽³⁾		0.4 μrad _{RMS}			
Gain Error		0.05 mrad			
Non-Linearity		0.005%			
Dynamic Performance					
Tracking Error		0 μsec			
Peak Acceleration ^(4,5)		288,000 m/s ²	224,000 m/s ²	80,000 m/s ²	56,000 m/s ²
Continuous Acceleration ^(4,6)		75,200 m/s ²	56,000 m/s ²	20,800 m/s ²	19,200 m/s ²
Positioning Speed ⁽⁴⁾		75 m/s	75 m/s	50 m/s	50 m/s
Marking Speed ^(4,7,8)		5 m/s			
Jump & Settle Time, 1 mm Move ^(4,9)		270 μsec	270 μsec	450 μsec	700 μsec
Stability					
Long-Term Drift ⁽³⁾	Offset	10 μrad/12 hrs			
	Gain	15 μrad/24 hrs			
Thermal Drift	Offset	10 ppm/24 hrs			
	Gain	10 μrad/°C			
		1 ppm/°C			
Mechanical Specifications					
Mass (AGV-HP)		4.1 kg	4.4 kg	5.1 kg	5.8 kg
Mass (AGV-HPO)		2.5 kg	2.6 kg	2.9 kg	3.1 kg
Material		Aluminum (Black Anodize and Blue Paint)			
Mean Time Before Failure		20,000 Hours			
NOTE: All specifications are per axis unless noted.					
(1) All angles are optical unless otherwise noted.					
(2) Without -AC air cooling option.					
(3) After an initial four hour warm-up, expect an ambient temperature variation of < ±0.5°.					
(4) Typical performance with f = 160 mm F-Theta objective.					
(5) Based on the maximum rated current of the motor.					
(6) Based on the rated rms current of the motor with -WC water cooling option; maximum continuous acceleration is 70% of this value without water cooling.					
(7) Achievable with <1% velocity error over continuous velocity portion of move.					
(8) Marking speed is dependent on allowable tracking error.					
(9) Settled to within 1% of move distance.					

Table 1-5: AGV-HP(O) Series Mirror Specifications

	Cooling Option	Aperture Size	Wavelength Coating									
			-W1	-W2	-W3	-W4	-W5	-W6	-W7	-W8	-W9	-W12
Maximum CW Laser Power (W)	No Cooling	10 mm	40	5	40	40	40	10	10	10	10	40
		14 mm	200	25	200	200	200	50	50	50	50	200
		20 mm	300	50	300	300	300	100	100	100	100	300
		30 mm	500	100	500	500	500	150	150	150	150	500
	Air Cooling	10 mm	80	10	80	80	80	20	20	20	20	80
		14 mm	400	50	400	400	400	100	100	100	100	400
		20 mm	600	100	600	600	600	200	200	200	200	600
		30 mm	1000	200	1000	1000	1000	300	300	300	300	1000
	Air and Water Cooling	10 mm	240	30	240	240	240	60	60	60	60	240
		14 mm	1200	150	1200	1200	1200	300	300	300	300	1200
		20 mm	1800	300	1800	1800	1800	600	600	600	600	1800
		30 mm	3000	600	3000	3000	3000	900	900	900	900	3000

1.4. Vacuum Operation

Contact the factory for information about operation in a vacuum environment.

This page intentionally left blank.

Chapter 2: Mechanical Specifications and Installation

IMPORTANT: This manual tells you how to carefully and correctly use and operate the AGV-HP(O).



- Read all parts of this manual before you install or operate the galvo or before you do maintenance to your system.
- To prevent injury to you and damage to the equipment, obey the precautions in this manual.
- All specifications and illustrations are for reference only and were complete and accurate as of the release of this manual. To find the newest information about this product, refer to www.aerotech.com.

If you do not understand the information in this manual, contact Aerotech Global Technical Support.



DANGER: Use of this product increases the risk of exposure to visible and/or invisible laser radiation.

- Do not stare into the laser beam, put your body parts in the laser area, or expose yourself to reflections from powerful beams.
- Wear certified laser safety eye protection.
- Avoid eye or skin exposure to direct or scattered radiation.



WARNING: Aerotech recommends that you only use a Class 1 HeNe laser to do alignments. If a Class 1 HeNe laser is not available, use the lowest power setting on the available laser and remote beam sensing techniques.



WARNING: Use the parameter file provided by the factory to configure the controller or permanent mechanical damage could occur.

2.1. Unpacking and Handling the Scan Head



IMPORTANT: To prevent the accumulation of condensation on the optical surfaces, allow the shipping case to sit at room temperature before you open it.



WARNING: It is the responsibility of the customer to safely and carefully lift and move the scan head. If you are not careful, you could adversely affect the performance of the AGV-HP(O).

- Do not use the cables or tubing as lifting points.
- Do not use the focal lens or exit aperture as a lift surface.
- Make sure that the lens cap is attached before you move the AGV-HP(O).
- Put the scan head on a soft surface when it is not attached to its mounting surface to protect the optics.



IMPORTANT: Wear clean, powder-free gloves when you handle optical components.

Lift only by the base of the scan head.

Carefully remove the AGV-HP(O) from its protective shipping container.

Before operating the AGV-HP(O), it is important to let it stabilize outside of the shipping case at room temperature for at least 12 hours. Allowing it to stabilize to room temperature will ensure that all of the alignments, preloads, and tolerances are the same as they were when tested at Aerotech. Use compressed nitrogen or clean, dry, oil-less air to remove any dust or debris that has collected during shipping.



IMPORTANT: Each AGV-HP(O) has a label that lists the system part number and serial number. These numbers are necessary to maintain or update system hardware and software. Locate this label and record the information for later reference.

2.2. Dimensions

Figure 2-1: AGV10HP-BE1 Galvanometer Scanner Dimensions

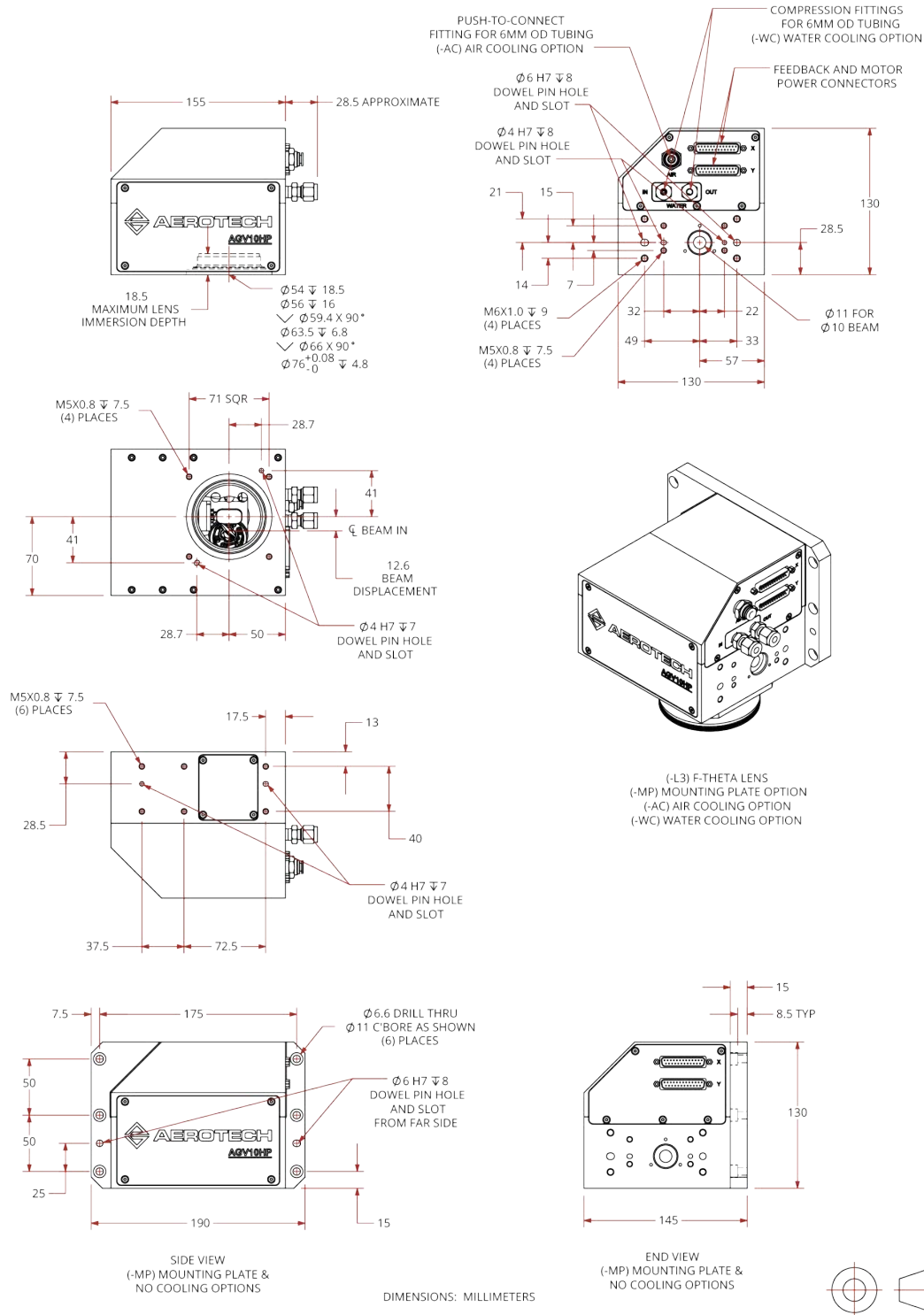
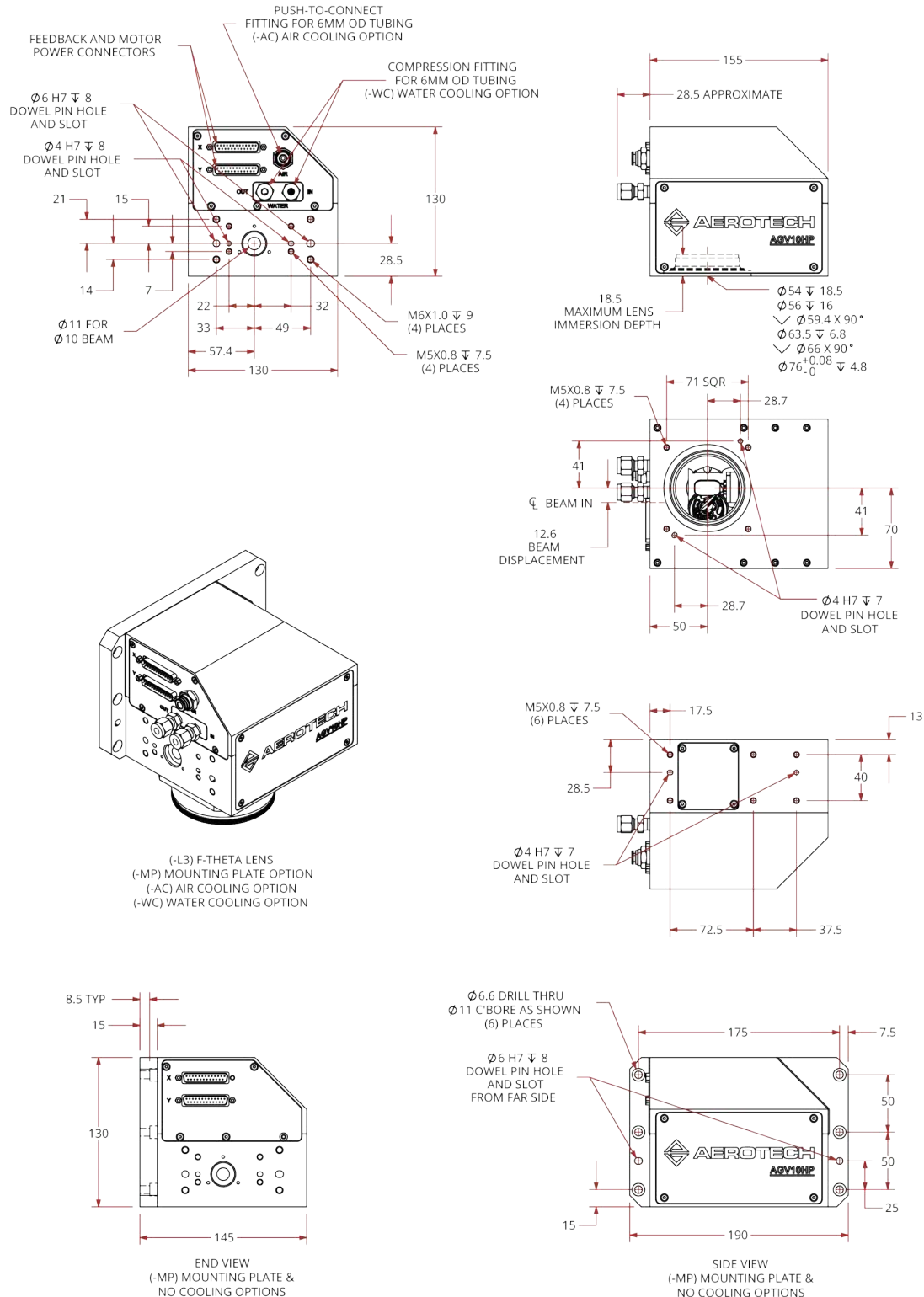

Figure 2-2: AGV10HP-BE2 Galvanometer Scanner Dimensions



DIMENSIONS: MILLIMETERS

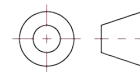
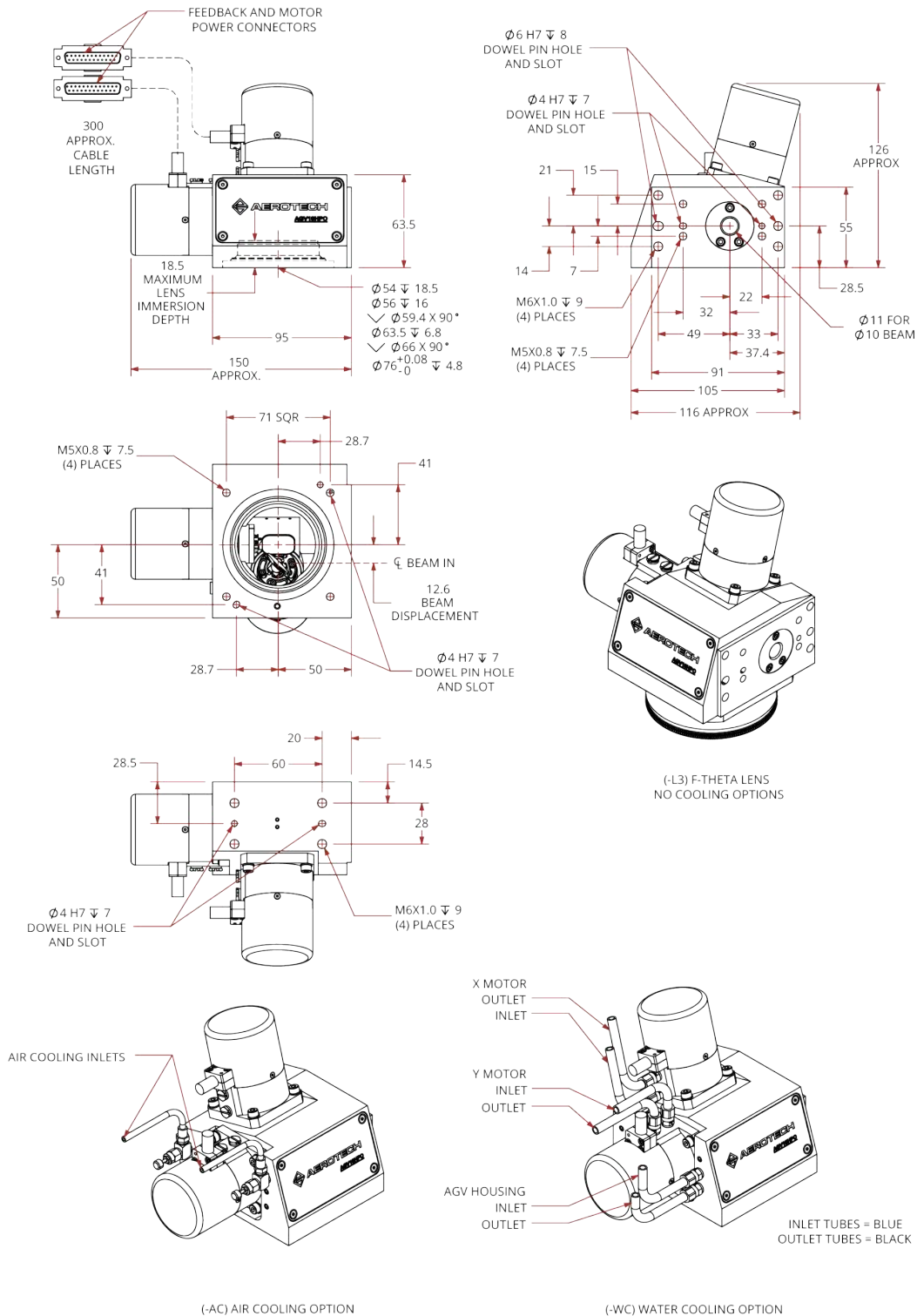

Figure 2-3: AGV10HPO-BE1 Galvanometer Scanner Dimensions



DIMENSIONS: MILLIMETERS

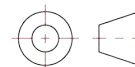
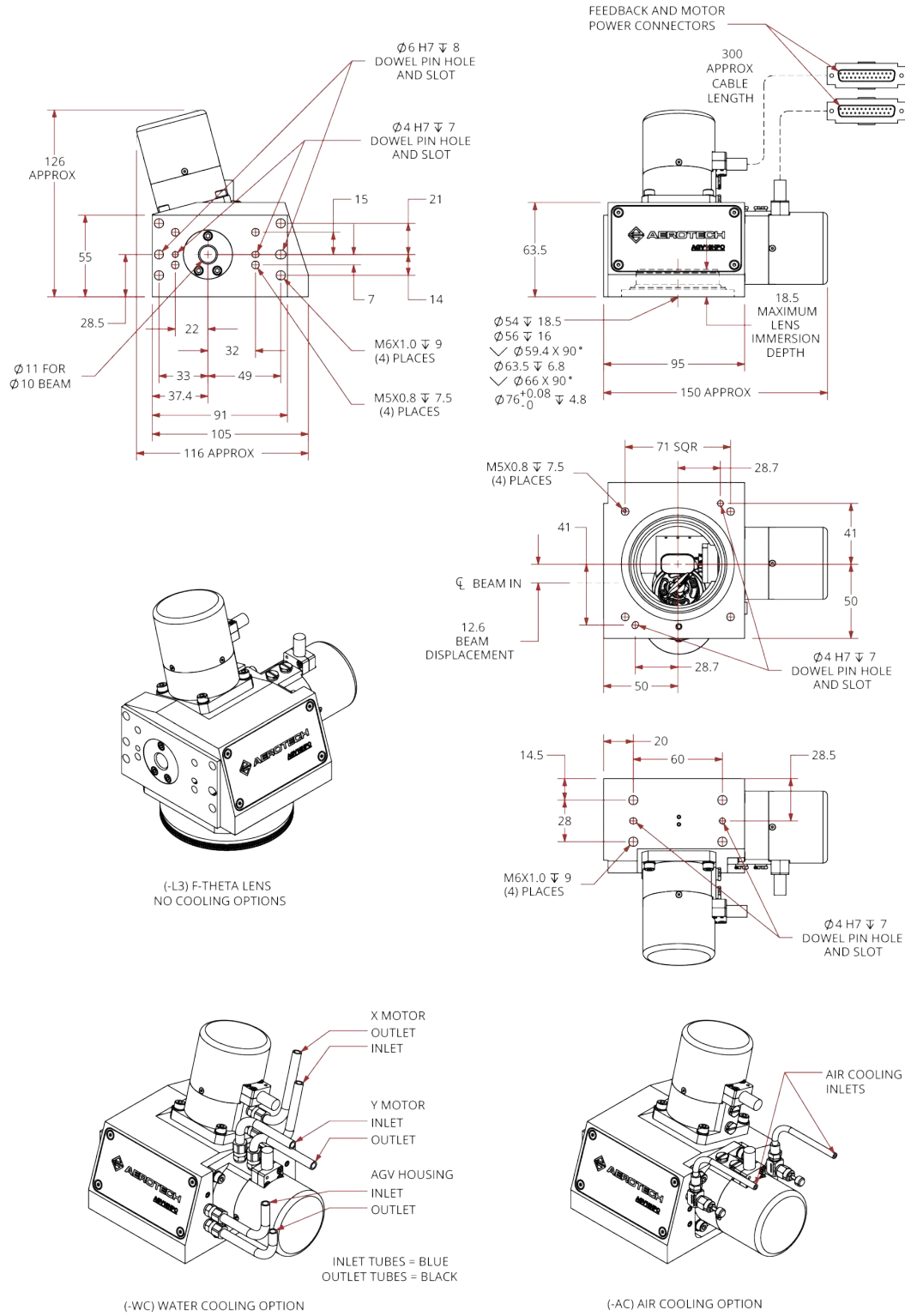

Figure 2-4: AGV10HPO-BE2 Galvanometer Scanner Dimensions



DIMENSIONS: MILLIMETERS



Figure 2-5: AGV14HP-BE1 Galvanometer Scanner Dimensions

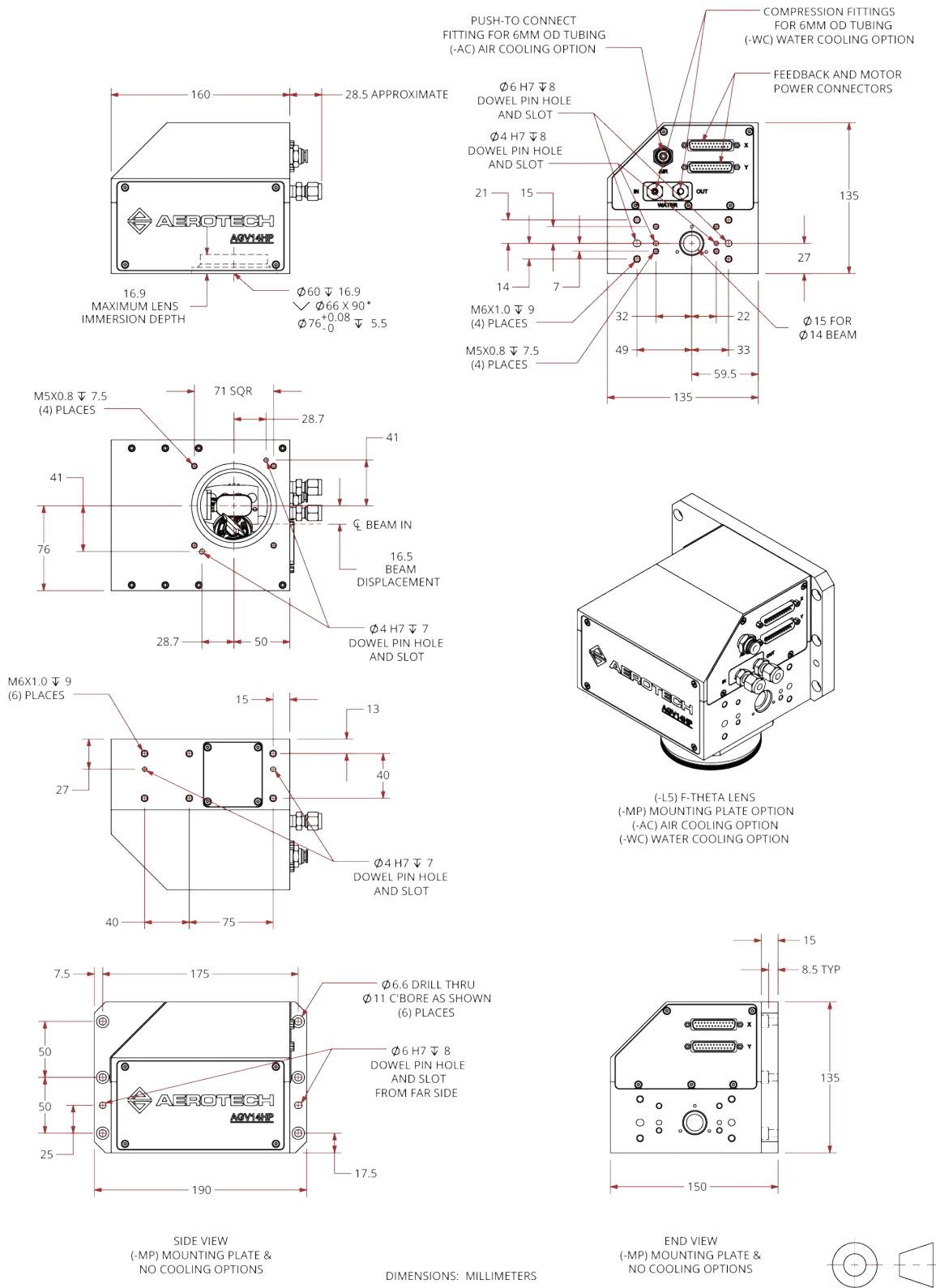
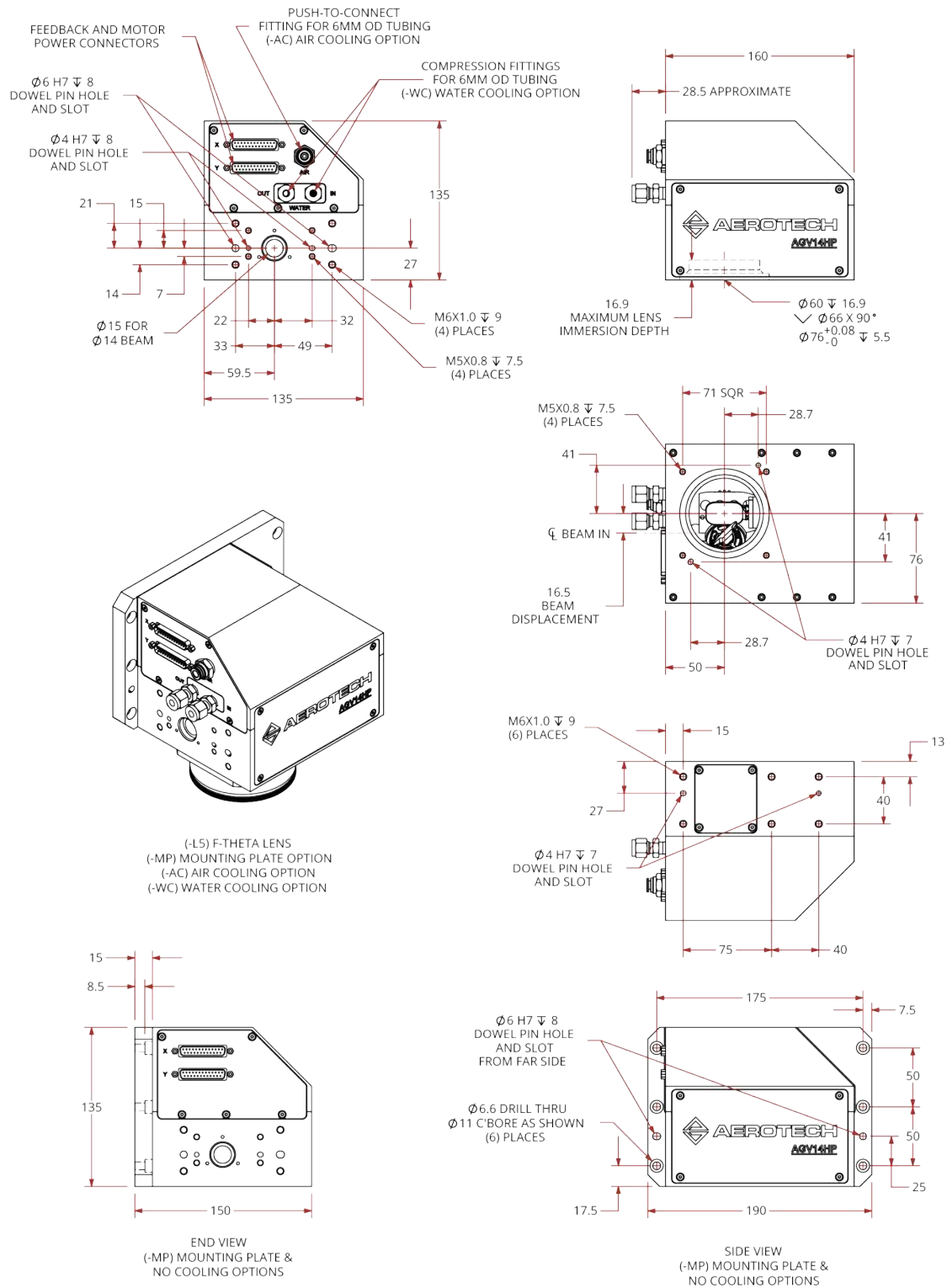

Figure 2-6: AGV14HP-BE2 Galvanometer Scanner Dimensions



DIMENSIONS: MILLIMETERS

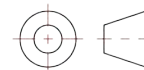

Figure 2-7: AGV14HPO-BE1 Galvanometer Scanner Dimensions

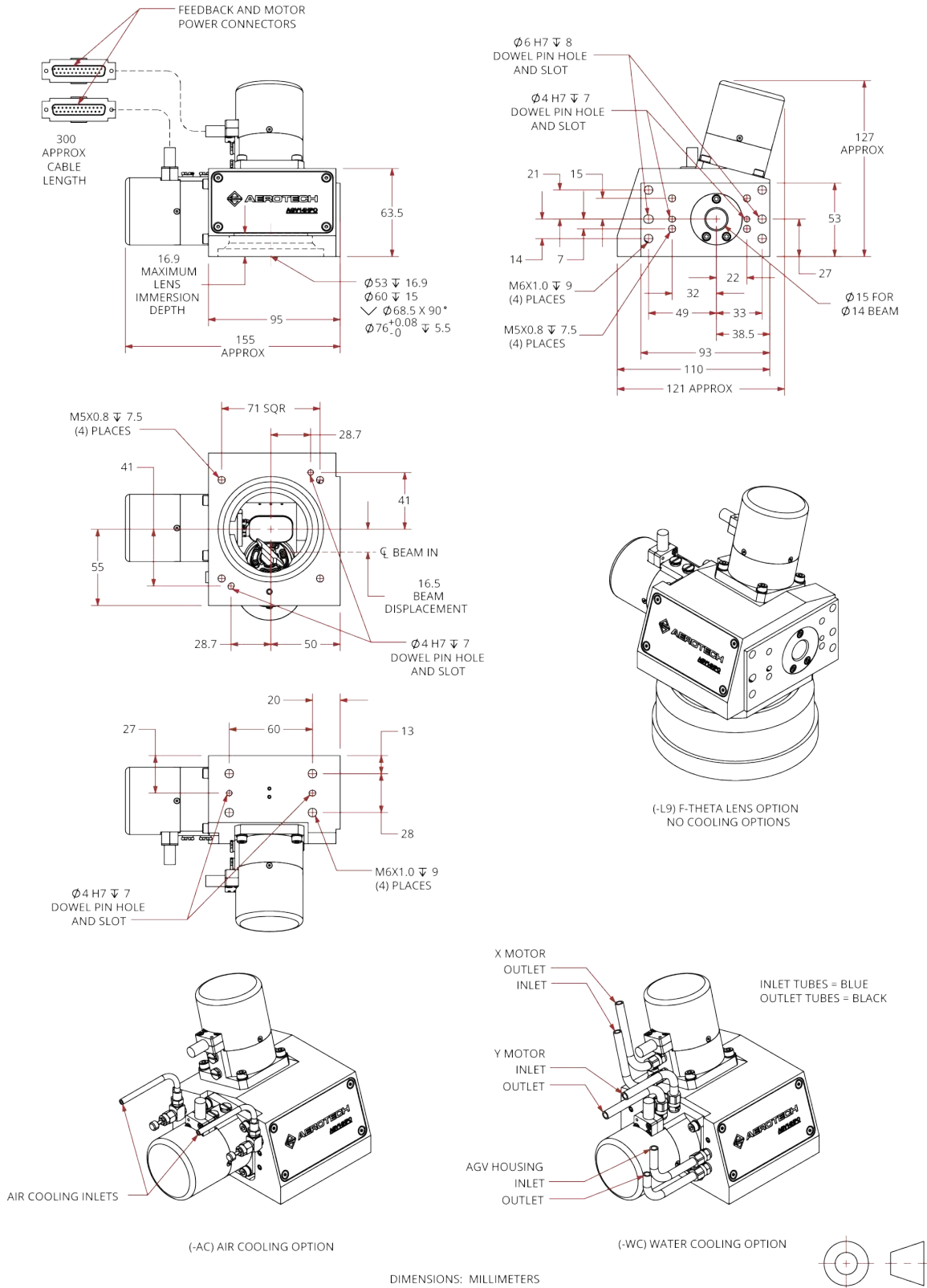

Figure 2-8: AGV14HPO-BE2 Galvanometer Scanner Dimensions

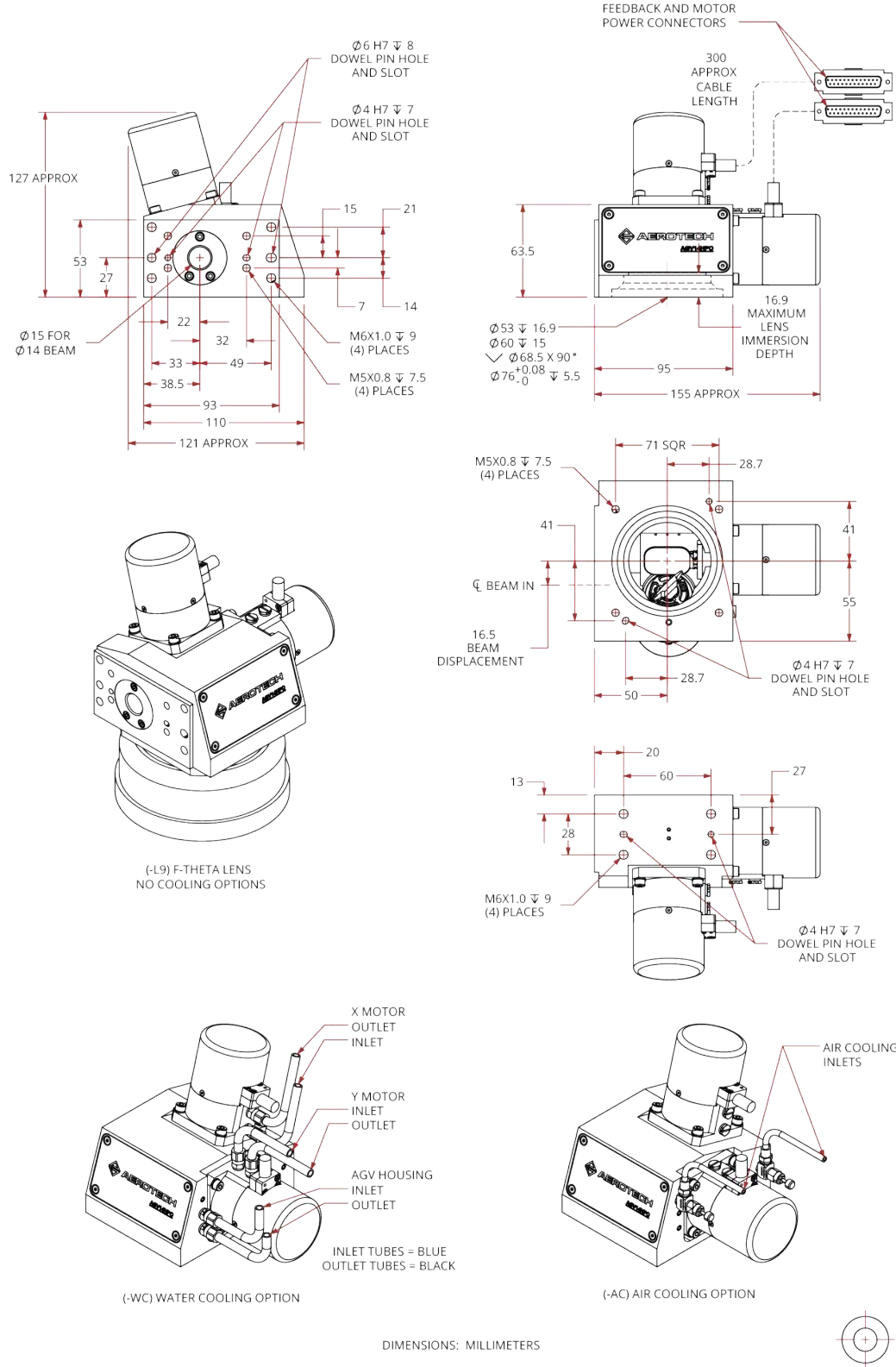

Figure 2-9: AGV20HP-BE1 Galvanometer Scanner Dimensions

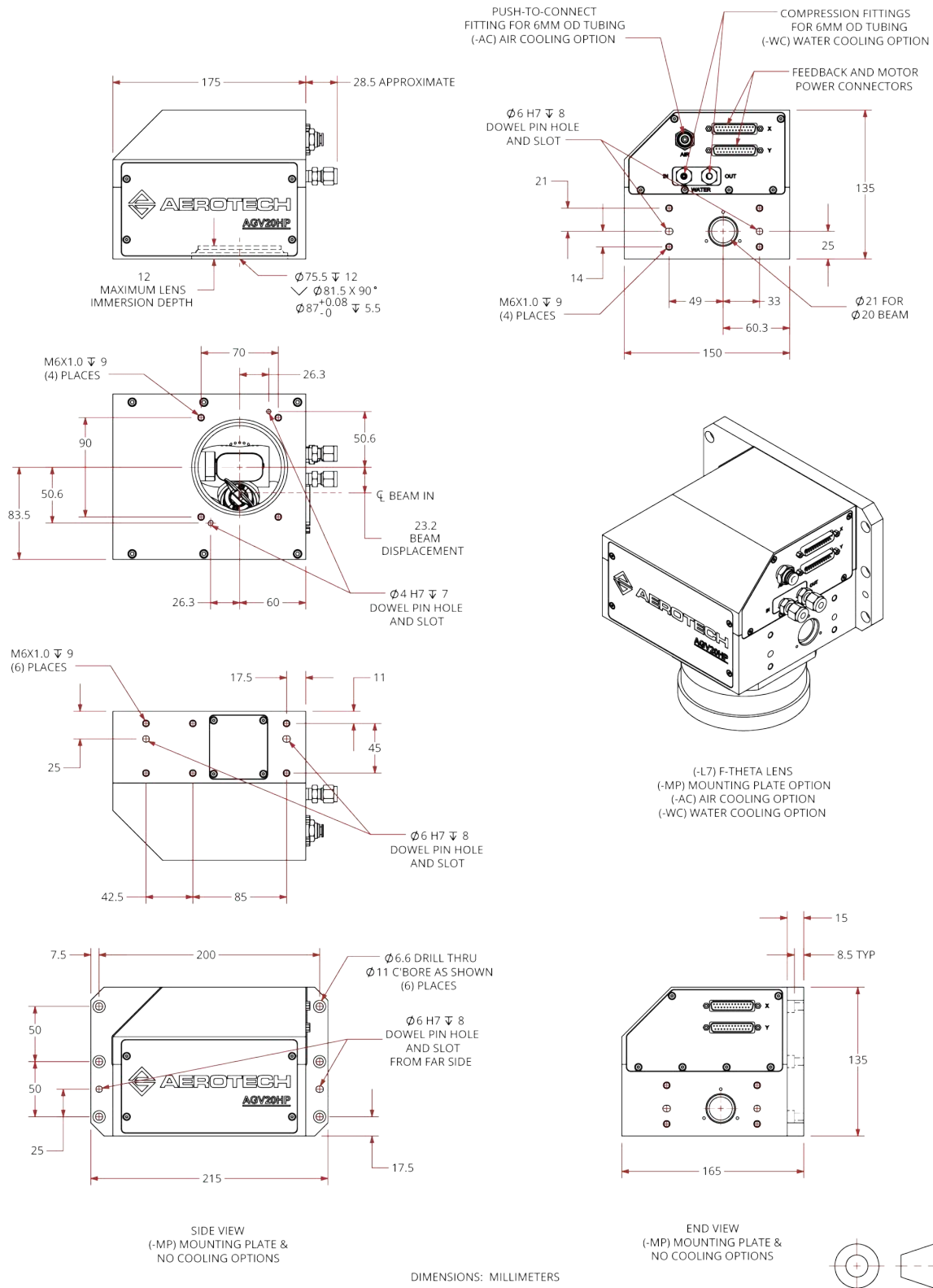

Figure 2-11: AGV20HPO-BE1 Galvanometer Scanner Dimensions

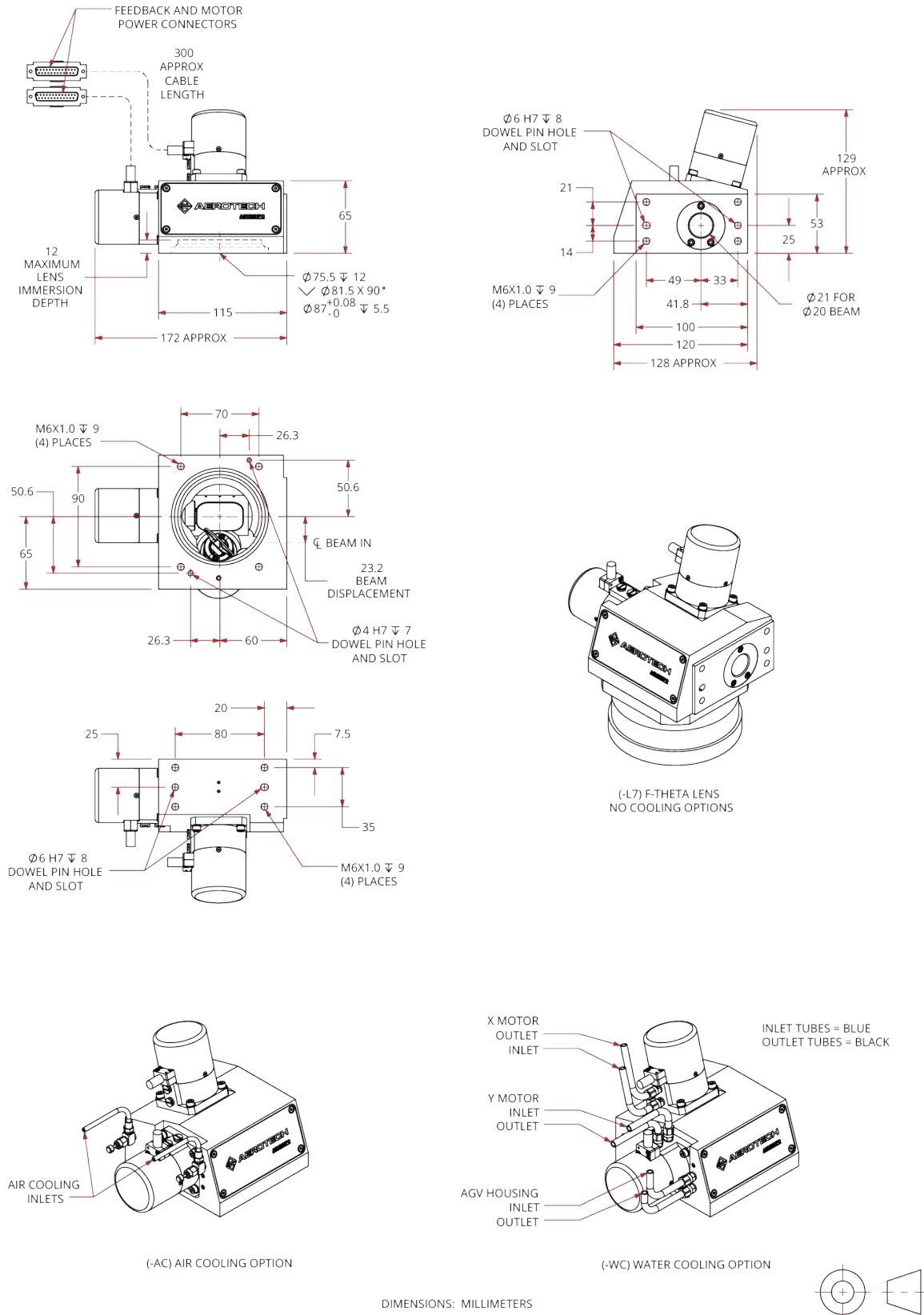
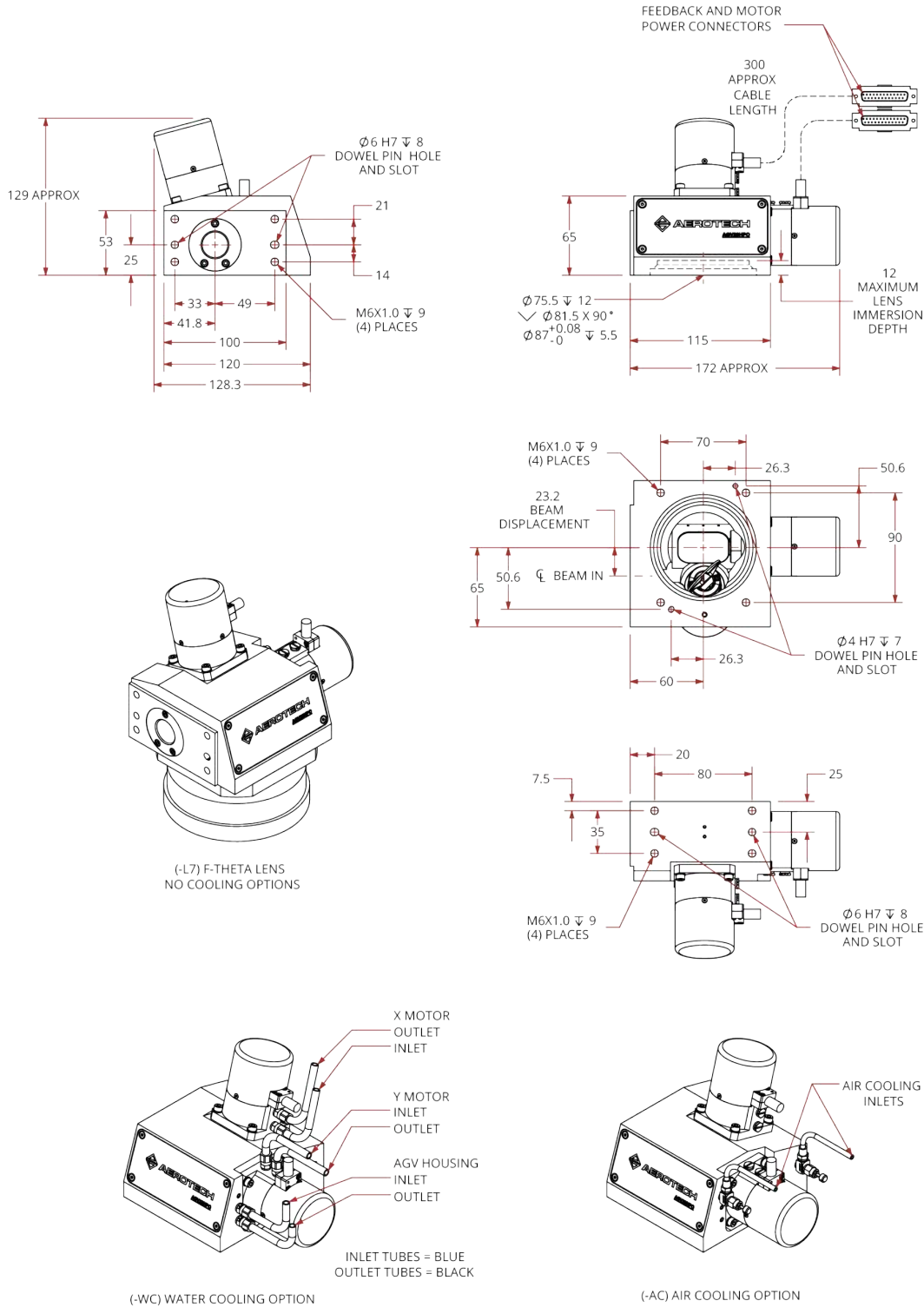

Figure 2-12: AGV20HPO-BE2 Galvanometer Scanner Dimensions



DIMENSIONS: MILLIMETERS

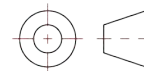
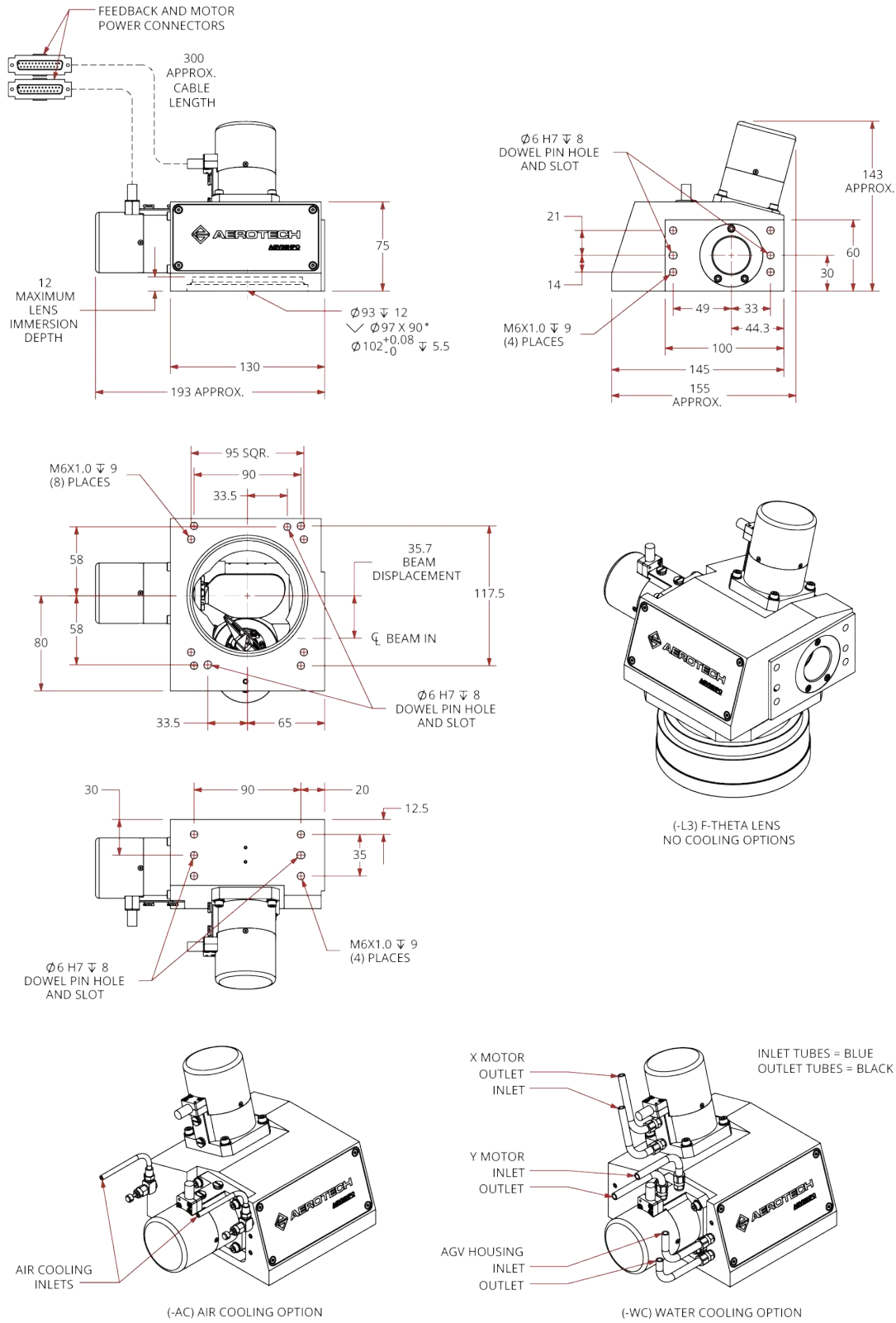

Figure 2-14: AGV30HPO-BE1 Galvanometer Scanner Dimensions



DIMENSIONS: MILLIMETERS



2.3. Securing the Scan Head to the Mounting Surface



WARNING: It is the responsibility of the customer to safely and carefully move and mount the scan head. If you are not careful, you could adversely affect the performance of the AGV-HP(O).

- Make sure that the lens cap is attached before you move the AGV-HP(O).
- Put the scan head on a soft surface when it is not attached to its mounting surface to protect the optics.

The mounting surface should be flat and have adequate stiffness in order to achieve the maximum performance from the AGV-HP(O) scan head. When an AGV-HP(O) is mounted to a non-flat surface, the scan head can be distorted as the mounting screws are tightened. This distortion will affect the alignment between the galvano motors and decrease the overall accuracy of the scan head. Adjustments to the mounting surface must be made before the scan head is secured.

Inspect the mounting surface for dirt or unwanted residue and clean if necessary. Use precision flatstones on the mounting surface to remove any burrs or high spots. Clean the mounting surface with a lint-free cloth and acetone or isopropyl alcohol and allow the cleaning solvent to completely dry. Gently place the stage on the mounting surface.



WARNING: The AGV-HP(O) is precision machined and verified for flatness at the factory.

- Do not machine the AGV-HP(O) housing. If you must machine a surface to achieve a required flatness, machine the mounting surface.
- Keep the use of shims to a minimum when you mount the AGV-HP(O) to the mounting surface. The use of shims could reduce the rigidity of the system.

The parallelism of the AGV-HP(O) focus plane to the physical work plane is important for deterministic spot sizes in the work plane. The required alignment precision between the AGV-HP(O) and the work plane are dependent on the working distance and depth of focus of the optical system. The alignment tolerance should be based on the variability acceptable in the optical system. Aerotech recommends that you align the bottom surface of the AGV parallel to the work plane within 25 μm as a starting point.



WARNING: To maintain accuracy, the mounting surface must be flat to within 3 μm per 50 mm.

There are several ways to mount the AGV-HP(O) scan head. Attaching the scan head directly with the mounting holes provided on the beam entrance plate of the head uses the least amount of hardware. Additional mounting holes are also provided on the back surface of the scan head. For applications where the scan head is to be mounted onto a bridge structure or onto the carriage of a gantry stage, the AGV-HP series scanners can be equipped with an optional mounting plate.

Refer to [Section 2.2.](#) for dimensional drawings that detail the mounting hole locations, quantity, and size.

ATTACH THE SCAN HEAD TO THE MOUNTING FLANGE

A general procedure for attaching the AGV-HP(O) scan head to a mounting flange is provided below. Note that the mounting flange must include appropriate features to match the threaded holes and the dowel holes and slots present on the AGV-HP(O) scan head.

1. Remove the plug from the beam entrance aperture of the scan head.



IMPORTANT: Retain the plug for future use. Reinstall the plug if you need to ship the scan head back to the factory for service.

2. Prepare the mounting flange and the mating surface of the scan head by stoning with precision flatstones to remove any burrs or high spots.
3. Clean the mounting flange and the mating surface of the scan head with the appropriate cleaners (isopropyl alcohol for the scan head).
4. Line up the dowel hole and slot features of AGV-HP(O) scan head with the dowel pins protruding from the mounting flange.
5. Install the scan head onto the pins.
6. Insert the appropriate hardware into the holes of the mounting flange. The screw length must be long enough to provide at least 1.0x diameter thread engagement.
7. Using an appropriate wrench, tighten the hardware. Alternate tightening of the screws so that the AGV-HP(O) scan head comes together evenly on the mounting flange.

2.4. Attaching the Focal Lens to the Scan Head



IMPORTANT: Wear clean, powder-free gloves when you handle optical components.

The procedure outlined in this section is provided as a general reference for how to remove or install a focal lens (F-Theta lenses). A lens adapter is required to attach the focal lens to the AGV-HP(O) series scan head. This lens adapter is supplied with optics configurations that include a focal lens. For AGV-HP(O) scan heads that are provided without a focal lens, the user is responsible for supplying both the F-Theta lens and the necessary lens adapter. Contact the factory for assistance with the design of an appropriate lens adapter if necessary.

Figure 2-15: Example of F-Theta Lens (Complete Assembly)

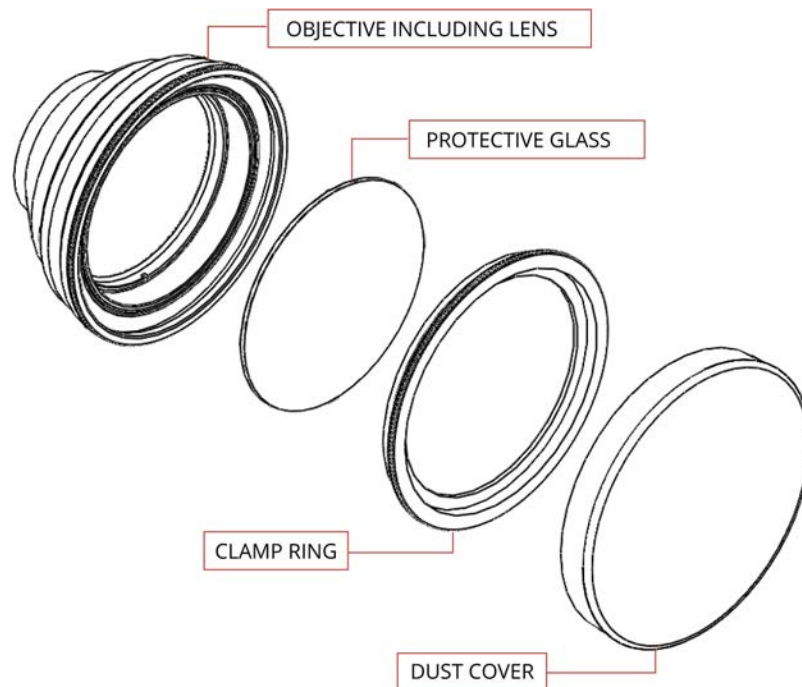

DANGER: Make sure that the laser is set in the "off" position and secured against accidental operation before you inspect or do maintenance to the focal lens.

1. Before you assemble the focal lens into the scan head, remove the dust cover(s) and inspect the lens elements and protective glass for dirt, scratches or cracks. Any lens component with a scratch or a crack must be replaced.
2. If the optics are dirty, use the procedure outlined in [Section 4.2](#) to clean them.
3. If necessary, use the clamp ring to install the protective glass over the front of the lens. Place the dust cover over the front of the lens.
4. Remove the plug from the beam exit aperture on the bottom of the scan head.
5. Make sure that the dowel pin in the lens adapter is aligned with the reference slot in the scan head and attach the lens adapter to the scan head using the appropriate hardware. The screw length must be long enough to provide at least 1.0x diameter thread engagement.
6. Screw the focal lens into the lens adapter until it seats and is positioned securely. Be careful not to cross-thread the housing of the lens assembly.
7. Remove the dust cover from the front of the focal lens.

To remove the focal lens, reverse the procedure outlined above.

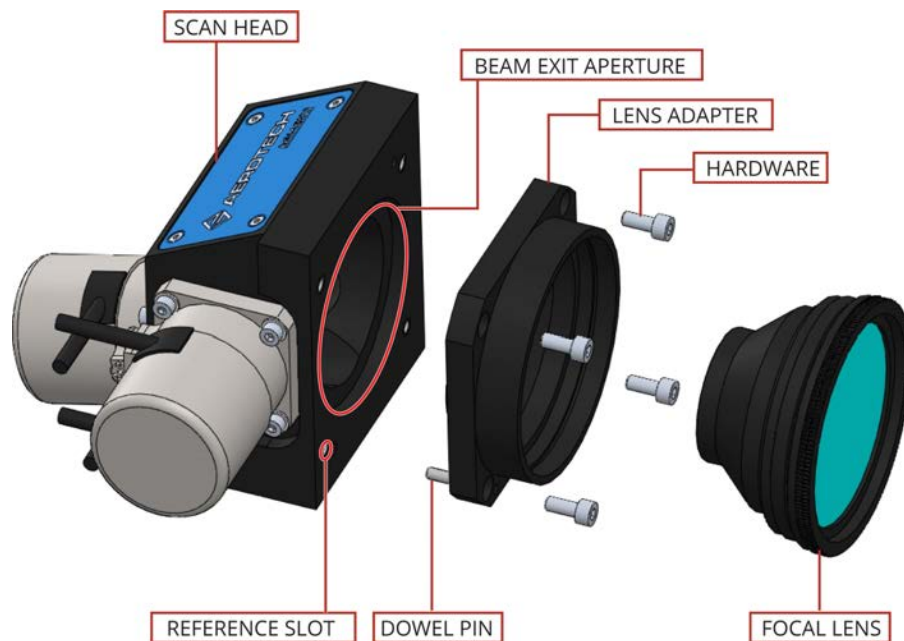

Figure 2-16: Assembly of Focal Lens to Scan Head (AGV-HP(O))

2.5. Air Requirements



WARNING: To prevent damage to the AGV-HP(O), do not attach a water hose to an air fitting or an air hose to a water fitting.



DANGER: High pressure air can cause severe injury.

- Lock out the source and bleed off the pressure before you do service to the equipment.
- Wear eye protection.

An air supply is needed for AGV-HP(O) models equipped with the -AC air cooling option. A gas supply pressure of 517 kPa to 586 kPa (75 psi to 85 psi) is required when using this feature. Gas must be delivered through a polyurethane air hose with an outer diameter (OD) of:

- AGV-HP: 6 mm OD (4 mm ID)
- AGV-HPO: 4 mm OD (2 mm ID)

Unless otherwise specified, a gas flow rate of 20 SLPM (standard liters per minute) at 550 kPa (80 psi) should be observed.

- If nitrogen is used, it must be 99.99% pure and filtered to 0.25 microns. [Recommended]
- If compressed air is used, it must be filtered to 0.25 microns, dry to 0° F dew point, and oil free.

The filtration requirement is necessary to prevent particles from damaging the optical surfaces of the turning mirrors.

Figure 2-17: Air-Cooling (-AC) Locations

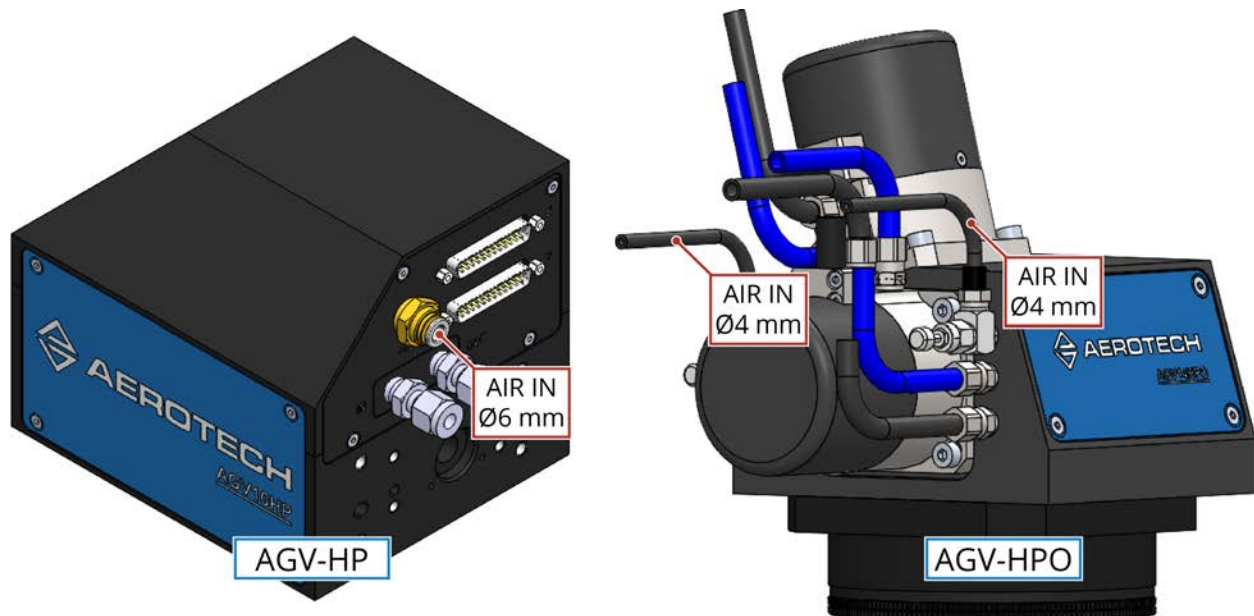

2.6. Water Requirements



WARNING: To prevent damage to the AGV-HP(O), do not attach a water hose to an air fitting or an air hose to a water fitting.



WARNING: Use distilled water as the coolant in the AGV-HP(O) water-cooling system. To prevent corrosion and damage to the cooling circuit, additives must be compatible with the materials found in the cooling circuit. These materials include brass, stainless steel, aluminum (plain or anodized), nickel plating, polyurethane, nylon, and nitrile rubber. If distilled water cannot be used, contact the factory to discuss the specifics of your application.

A supply of coolant is necessary for AGV-HP(O) models furnished with the -WC water cooling option. This feature requires a source of distilled, temperature-controlled water. You could use a corrosion inhibitor additive meant for multi-metal cooling channels to help increase the life of components in the water-cooling circuit. Aerotech recommends using an appropriately sized chiller capable of delivering 0.35 GPM (gallons per minute) at 60 psid. The coolant must be delivered and retrieved from the scan head via appropriate hoses with outer diameters of 6 mm.

Figure 2-18: Water Cooling (-WC) Locations

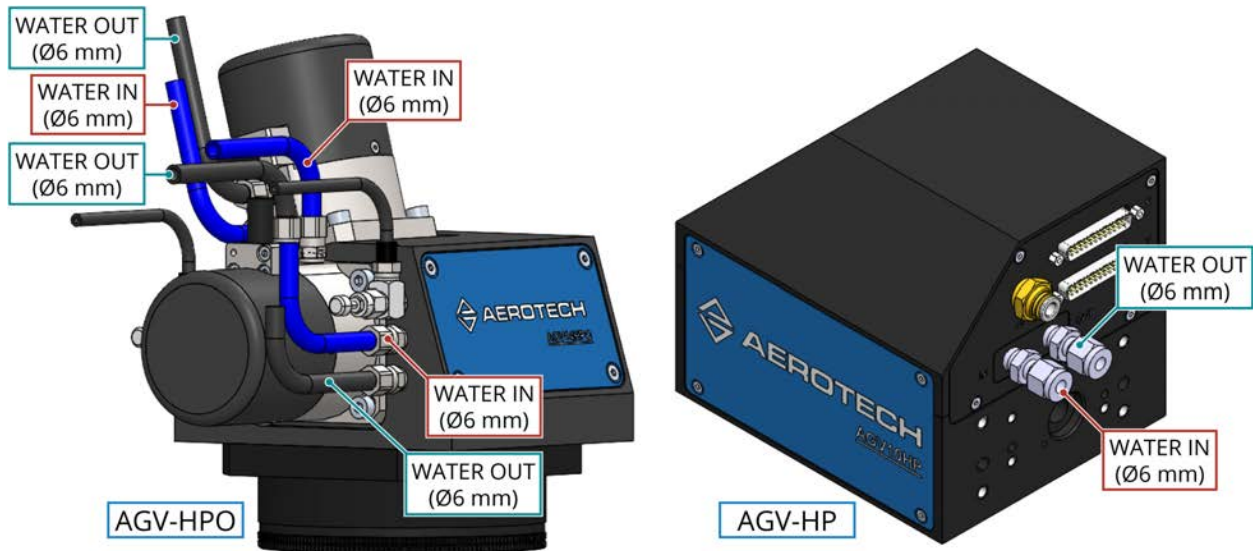

Chapter 3: Electrical Specifications and Installation



DANGER: To decrease the risk of electrical shock, injury, death, and damage to the equipment, obey the precautions that follow.

- Electrical installation must be done by qualified personnel.
- Before you do maintenance to the equipment, disconnect the electrical power.
- Before you connect wires to this product, disconnect the electrical power.
- Make sure that all components are grounded correctly and that they obey the local electrical safety requirements.
- It is the responsibility of the system integrator or qualified installer to determine and meet all safety and compliance requirements when they integrate the AGV-HP(O) into a completed system.



WARNING: To prevent damage to the equipment and decrease the risk of electrical shock and injury, obey the precautions that follow.

- Only trained operators should operate this equipment.
- Use this product only in environments and operating conditions that are approved in this manual.

Electrical installation requirements will depend on the ordered product options. Installation instructions in this section are for Aerotech products equipped with standard Aerotech motors intended for use with an Aerotech motion control system. Contact Aerotech for further information on products that are otherwise configured.

Aerotech motion control systems are adjusted at the factory for optimum performance. When the AGV-HP(O) is part of a complete Aerotech motion control system, setup should only require that you connect the galvo to the appropriate drive chassis with the cables provided. Labels on the system components should indicate the appropriate connections.

If system level integration was purchased, an electrical drawing that shows the system interconnects has been supplied with the system (separate from this documentation).

The electrical wiring from the motor and encoder are integrated at the factory. Refer to the sections that follow for standard motor wiring and connector pinouts.

3.1. Motor and Feedback Connectors



DANGER: To decrease the risk of electrical shock, injury, death, and damage to the equipment, obey the precautions that follow.

- Make sure that all components are grounded correctly and that they obey the local electrical safety requirements.
- It is the responsibility of the system integrator or qualified installer to determine and meet all safety and compliance requirements when they integrate the AGV-HP(O) into a completed system.
- Restrict access to the galvo when it is connected to a power source.

If the AGV-HP(O) is built with standard Aerotech motors and encoders, it will arrive from the factory completely wired and assembled.

The AGV scan heads contain galvano motors with dual analog encoder feedback. Both the primary and secondary position feedback signals of each galvano motor must be tuned for optimal performance. For help on how to adjust the gain, offset, and phase balance for each channel, refer to the Automation1 or A3200 Help system for more information. For controller information, refer to the Nmark GCL or GL4 Controller Hardware Manual for more information.



IMPORTANT: The protective ground connection of the AGV-HP(O) provides motor frame ground protection only. Additional ground and safety precautions are required for applications that require access to the AGV-HP(O) while it is energized.

Table 3-1: Motor and Feedback Connector Pinouts

Pin	Description	Connector
Case	Cable Shield	
1	SIN1+ (Encoder Sine 1+)	
2	COS1+ (Encoder Cosine 1+)	
3	5V Common Ground	
4	SIN2+ (Encoder Sine 2+)	
5	COS2+ (Encoder Cosine 2+)	
6	+ /CW LMT (The limit signal that shows the maximum permitted machine travel in positive or clockwise encoder counts.)	
7	MRK+ (Encoder Marker+)	
8	Encoder 5V Supply Input	
9	Reserved	
10	Reserved	
11	Frame Ground	
12	Motor +	
13	Motor +	
14	SIN1- (Encoder Sine 1-)	
15	COS1- (Encoder Cosine 1-)	
16	5V Common Ground	
17	SIN2- (Encoder Sine 2-)	
18	COS2- (Encoder Cosine 2-)	
19	- /CCW LMT (The limit signal that shows the maximum permitted machine travel in negative or counterclockwise encoder counts.)	
20	MRK- (Encoder Marker-)	
21	5V Common Ground	
22	5V Common Ground	
23	Frame Ground	
24	Motor -	
25	Motor -	

Table 3-2: Mating Connector Part Numbers for the Motor and Feedback Connector

Mating Connector	Aerotech P/N	Third Party P/N
25-Socket D-Connector	ECK00300	FCI DB25S064TLF
Backshell	ECK00656	Amphenol 17E-1726-2

3.2. Motor and Feedback Wiring

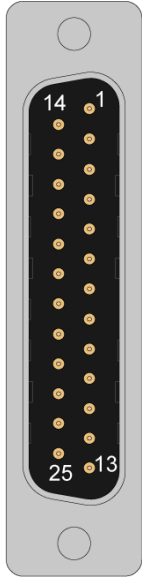

DANGER: To decrease the risk of electrical shock, injury, death, and damage to the equipment, obey the precautions that follow.

- Make sure that all components are grounded correctly and that they obey the local electrical safety requirements.
- It is the responsibility of the system integrator or qualified installer to determine and meet all safety and compliance requirements when they integrate the AGV-HP(O) into a completed system.
- Restrict access to the galvo when it is connected to a power source.

AGV-HP(O) scan heads are wired and assembled at the factory. Contact your Aerotech representative if you have any questions on system configuration. For cable drawings, refer to the documentation that shipped with your system.

Table 3-3: Aerotech Motor and Feedback Cable Part Numbers

Aerotech Controller	Nmark GCL or Automation1 GL4	
Cable Application	Standard	Hi-Flex
Interface Cable Part Number	C23680-xxx ^(1,2)	C23690-xxx ^(1,2)
(1) -xxx = Cable Length in Decimeters (1 Decimeter = 3.937 inches)		
(2) Contact the factory for standard and custom length cables		

Table 3-4: Wire Gauge and Insulation Specifications

	Current	Wire Gauge: mm ² (AWG)	Minimum Recommended Insulation Voltage (V)
AGV10HP(O)	7.1	1.3 (16)	60
AGV14HP(O)	7.1	1.3 (16)	60
AGV20HP(O)	7.1	1.3 (16)	60
AGV30HP(O)	5.6	1.3 (16)	60

Figure 3-1: Motor and Feedback Wiring

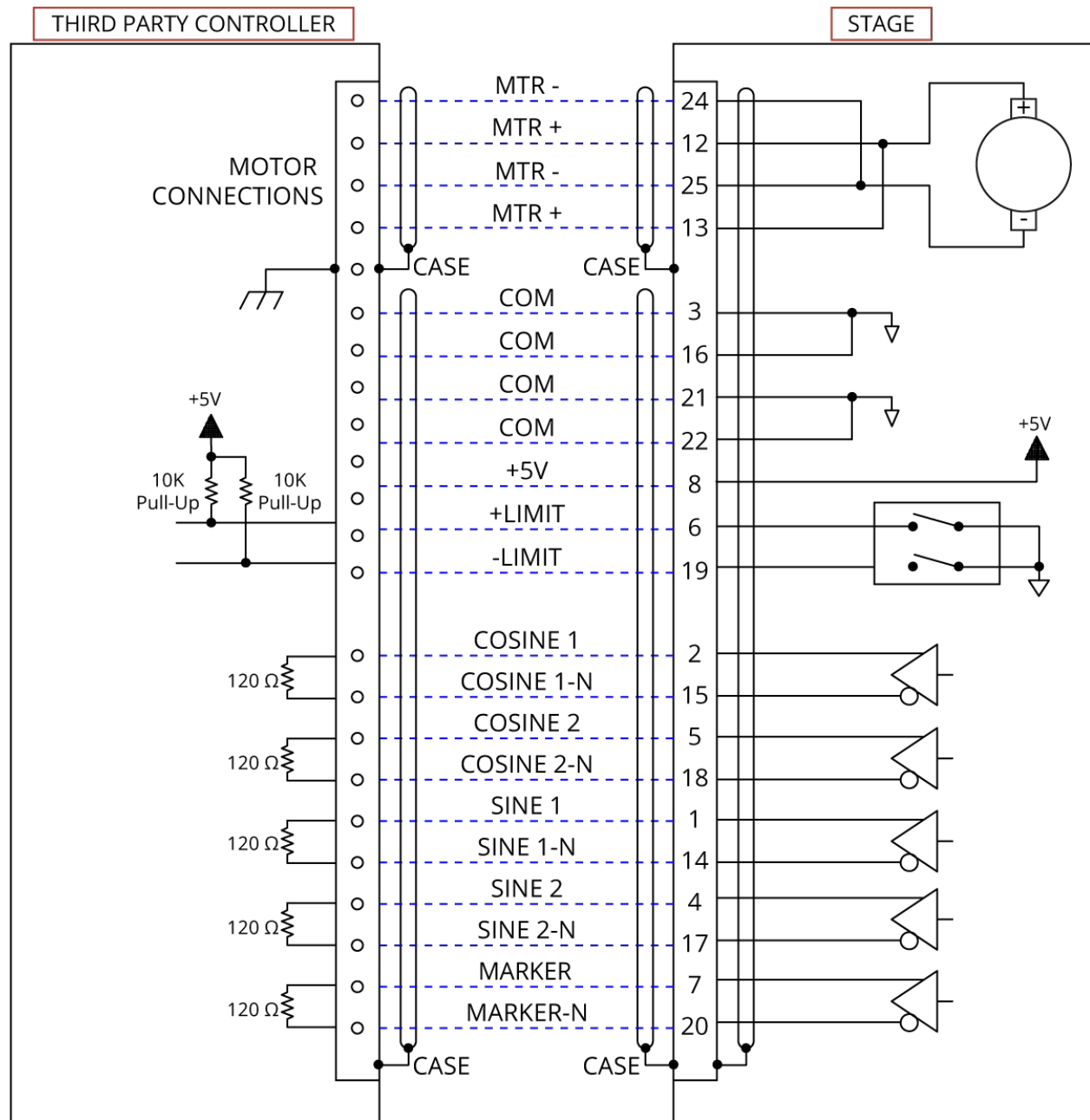

3.3. Motor and Feedback Specifications

Table 3-5: Motor and Feedback Specifications

Feedback Specifications		
	AGV10HP(O), AGV14HP(O), AGV20HP(O)	AGV30HP(O)
Supply Voltage	5 V	
Supply Current	250 mA	
Output Signals	Sinusoidal Type (Incremental Encoder): 1 V _{pk-pk} into 120 Ω Load (differential signals SIN+, SIN-, COS+, COS- are .5 V _{pk-pk} relative to ground.)	
Encoder Resolution	4096 lines/revolution	
Motor Specifications		
	AGV10HP(O), AGV14HP(O), AGV20HP(O)	AGV30HP(O)
BEMF Constant	1.4 V/krpm	4.3 V/krpm
Max Current	5 A	5 A
Resistance	1.5 Ω	3.1 Ω
Inductance	170 μH	675 μH
Maximum Bus Voltage	80 V	80 V
Number of Poles	2	2

3.4. Limits, Marker, and Machine Direction

Aerotech stages are configured to have positive and negative "machine" directions. The machine direction defines the phasing of the feedback and motor signals and is dictated by the stage wiring (refer to [Section 3.5](#) for Motor and Feedback phasing information). Programming direction of a stage is set by the controller that is used to move the stage. The galvo motors for each axis have internal electrical limits for both positive and negative machine direction motion. Programming direction is typically selectable in the controller, while machine direction is hardwired in the stage.

Figure 3-2: -BE1 Galvo X-Axis Machine Direction (front)



Figure 3-3: -BE1 Galvo Y-Axis Machine Direction (side)

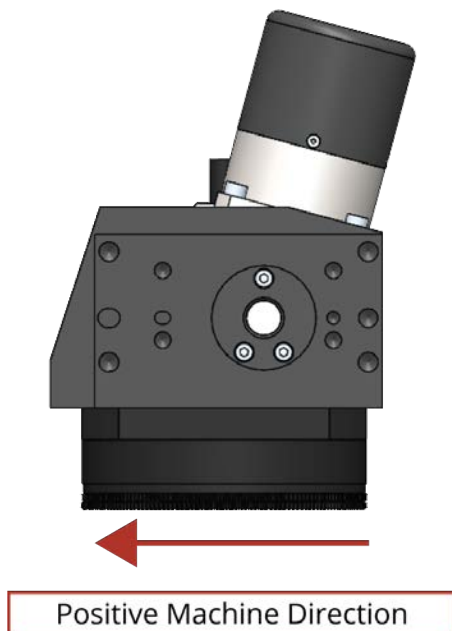

Figure 3-4: -BE2 Galvo X-Axis Machine Direction (front)

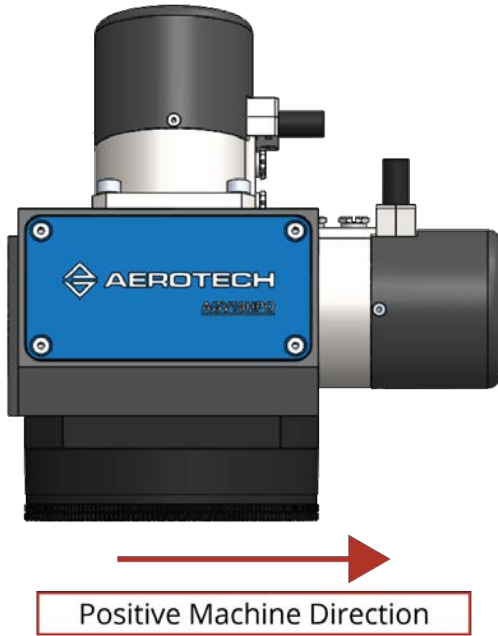
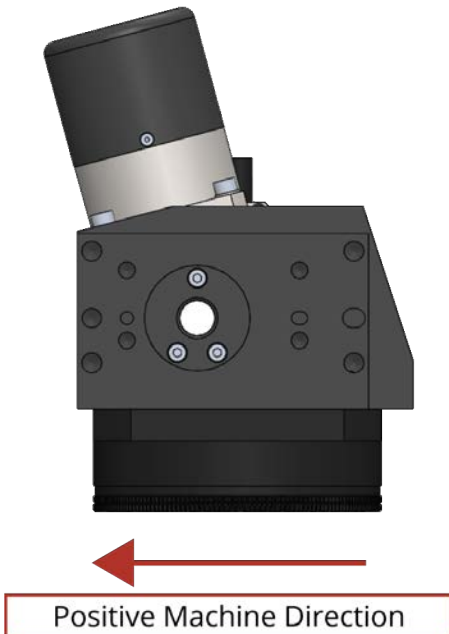
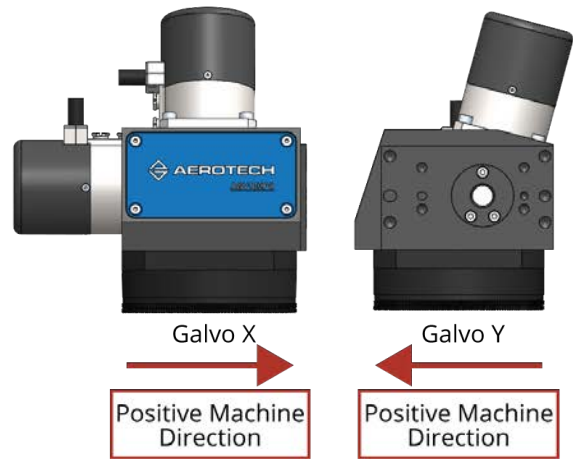
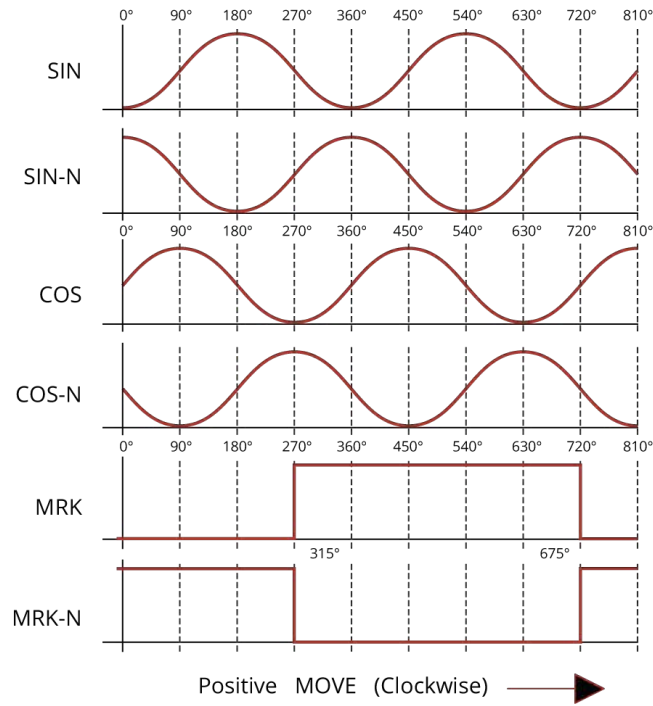

Figure 3-5: -BE2 Galvo Y-Axis Machine Direction (side)



3.5. Feedback Phasing

Figure 3-6: Analog Encoder Phasing Reference Diagram



This page intentionally left blank.

Chapter 4: Maintenance



DANGER: To decrease the risk of electrical shock, injury, death, and damage to the equipment, obey the precautions that follow.

- All service and maintenance must be done by approved personnel.
- Before you do maintenance to the equipment, disconnect the electrical power.
- Before you connect wires to this product, disconnect the electrical power.
- Restrict access to the galvo when it is connected to a power source.



WARNING: Keep the scan head free of foreign matter and moisture to prevent a reduction in its performance and life expectancy.

The AGV-HP(O) series scan head is designed to be dust resistant except at the beam entrance and beam exit apertures. The scan head does not require any maintenance other than periodic cleaning. Included in this chapter are recommended cleaning solvents.

4.1. Service and Inspection Schedule

Until you can find the correct inspection interval for your system, set the interval for once a month. Use the system application(s) and conditions (duty cycle, speed, and environment) to define the inspection interval.

Monthly inspections should include but not be limited to:

- Visually inspect the galvo, components, and cables.
- Re-tighten loose connectors.
- Replace or repair damaged cables.
- Clean the AGV-HP(O) and any components and cables as needed.
- Repair any damage before you operate the AGV-HP(O).
- Inspect and perform an operational check on all safeguards and protective devices.

It is usually not possible for Aerotech field service personnel to do repairs and/or replace components. Contact Aerotech Global Technical Support for more information and to determine if the AGV-HP(O) should be sent back to the factory for maintenance.

4.2. Cleaning and Lubrication

There are no elements on the AGV-HP(O) that require lubrication.

Before you use a cleaning solvent on any part of the AGV-HP(O), blow away small particles and dust with nitrogen or, less preferably, clean, dry, compressed air.

Use isopropyl alcohol on a lint-free cloth to clean any external metal surface of the AGV-HP(O).

4.2.1. Focal Lens and Protective Glass

Optical surfaces that are contaminated with dirt and debris result in increased absorption of laser radiation. Over time, this contamination can cause the optical surfaces to absorb enough heat to cause permanent burn damage. There are several different kinds of optical surface contamination:

- Airborne particles in the ambient atmosphere – dust, grease, etc.
- Products from the laser process – vapors, back spatter, burned-in particles, etc.
- Organic contamination – particles produced by talking, coughing, or sneezing near the optical surfaces.

Wherever possible, protect the exposed optics to avoid contamination. However, since contamination cannot be completely avoided, you will have to periodically clean the optical system. Regularly inspect and clean the optical surfaces to help prevent permanent damage.



WARNING: Contamination from the laser process can cause irreversible damage to the optical surfaces. To help minimize contamination, use a disposable protective glass window and/or an exhaust or vacuum system.

Optical materials and coatings are relatively soft substances and incorrect cleaning techniques will result in surface damage and drastically reduced component lifetime. The cleaning procedure for the AGV-HP(O) is intended to help prolong the component lifetime.



IMPORTANT: Wear clean, powder-free gloves when you handle optical components.



DANGER: Make sure that the laser is set in the "off" position and secured against accidental operation before you inspect or do maintenance to the focal lens.



WARNING: If the focal lens does not have a protective glass window, take extra care when you clean the focal lens.

Cleaning Procedure

1. Use compressed nitrogen or clean, dry, oil-less air to remove any loose particles from the surface.
2. Moisten an appropriate lint-free lens cleaning cloth with isopropyl alcohol.
3. Fold the cloth over such that one folded (straight) edge will serve as the leading edge during the wiping motion.
4. Place the folded (straight) edge of the cloth onto one end of the optical surface. Applying very minimal pressure, slowly move the cloth over the optical component to the opposite end. Never bear down hard, scrub, or wipe in a circular motion when cleaning an optical surface.
5. Remove any liquid residue with a dry lint-free lens cleaning cloth or by blow it off in one direction with compressed nitrogen or clean, dry, oil-less air.
6. Repeat this procedure, using a new lint-free lens cleaning cloth for each repetition, until the surface is completely clean.

4.2.2. Turning Mirrors



WARNING: Never touch the reflective surface of a turning mirror. Turning mirror surfaces are extremely delicate and can be easily damaged.



IMPORTANT: Wear clean, powder-free gloves when you handle optical components.

The reflective surfaces of the turning mirrors are extremely sensitive and should only be cleaned when it is absolutely necessary and only by experienced personnel. In many cases, minor imperfections in the surface of the mirror can be less harmful than the surface damage caused by repeated cleaning.

When cleaning the turning mirrors becomes an absolute necessity (to remove fingerprints from the reflective surfaces, for example), carefully follow the same procedure outlined in [Section 4.2.1](#).

4.3. Troubleshooting

Table 4-1: Troubleshooting

Symptom	Possible Cause	Possible Solution
Scanners will not move.	Controller trap or fault.	Refer to the controller documentation.
	Motor and Feedback connections	Refer to Section 3.1. , Section 3.2. , and the controller documentation.
Scanners move uncontrollably	Gains not optimized	Refer to the controller documentation for tuning instructions.
	Encoder signals not optimized	Refer to the controller documentation for encoder tuning instructions.
	Motor and Feedback connections	Refer to Section 3.1. , Section 3.2. , and the controller documentation
Scanners oscillate or squeal	Gains not optimized	Refer to the controller documentation for tuning instructions.
	Encoder signals not optimized	Refer to the controller documentation for encoder tuning instructions.
Reduction in power as the laser beam passes through the scan head	Optical surfaces contaminated with dirt and debris	Refer to Section 4.2.
	Optical surfaces damaged	Contact Aerotech service and/or a lens supplier.
AGV-HP(O) scanner does not find marker during homing cycle.	Motor and Feedback connections	Refer to Section 3.1. , Section 3.2. , and the controller documentation.
	Mechanical stops have shifted	Contact Aerotech service.

Appendix A: Warranty and Field Service

Aerotech, Inc. warrants its products to be free from harmful defects caused by faulty materials or poor workmanship for a minimum period of one year from date of shipment from Aerotech. Aerotech's liability is limited to replacing, repairing or issuing credit, at its option, for any products that are returned by the original purchaser during the warranty period. Aerotech makes no warranty that its products are fit for the use or purpose to which they may be put by the buyer, whether or not such use or purpose has been disclosed to Aerotech in specifications or drawings previously or subsequently provided, or whether or not Aerotech's products are specifically designed and/or manufactured for buyer's use or purpose. Aerotech's liability on any claim for loss or damage arising out of the sale, resale, or use of any of its products shall in no event exceed the selling price of the unit.

THE EXPRESS WARRANTY SET FORTH HEREIN IS IN LIEU OF AND EXCLUDES ALL OTHER WARRANTIES, EXPRESSED OR IMPLIED, BY OPERATION OF LAW OR OTHERWISE. IN NO EVENT SHALL AEROTECH BE LIABLE FOR CONSEQUENTIAL OR SPECIAL DAMAGES.

Return Products Procedure

Claims for shipment damage (evident or concealed) must be filed with the carrier by the buyer. Aerotech must be notified within thirty (30) days of shipment of incorrect material. No product may be returned, whether in warranty or out of warranty, without first obtaining approval from Aerotech. No credit will be given nor repairs made for products returned without such approval. A "Return Materials Authorization (RMA)" number must accompany any returned product(s). The RMA number may be obtained by calling an Aerotech service center or by submitting the appropriate request available on our website (www.aerotech.com). Products must be returned, prepaid, to an Aerotech service center (no C.O.D. or Collect Freight accepted). The status of any product returned later than thirty (30) days after the issuance of a return authorization number will be subject to review.

Visit [Global Technical Support Portal](#) for the location of your nearest Aerotech Service center.

Returned Product Warranty Determination

After Aerotech's examination, warranty or out-of-warranty status will be determined. If upon Aerotech's examination a warranted defect exists, then the product(s) will be repaired at no charge and shipped, prepaid, back to the buyer. If the buyer desires an expedited method of return, the product(s) will be shipped collect. Warranty repairs do not extend the original warranty period.

Fixed Fee Repairs - Products having fixed-fee pricing will require a valid purchase order or credit card particulars before any service work can begin.

All Other Repairs - After Aerotech's evaluation, the buyer shall be notified of the repair cost. At such time the buyer must issue a valid purchase order to cover the cost of the repair and freight, or authorize the product(s) to be shipped back as is, at the buyer's expense. Failure to obtain a purchase order number or approval within thirty (30) days of notification will result in the product(s) being returned as is, at the buyer's expense.

Repair work is warranted for ninety (90) days from date of shipment. Replacement components are warranted for one year from date of shipment.

Rush Service

At times, the buyer may desire to expedite a repair. Regardless of warranty or out-of-warranty status, the buyer must issue a valid purchase order to cover the added rush service cost. Rush service is subject to Aerotech's approval.

On-site Warranty Repair

If an Aerotech product cannot be made functional by telephone assistance or by sending and having the customer install replacement parts, and cannot be returned to the Aerotech service center for repair, and if Aerotech determines the problem could be warranty-related, then the following policy applies:

Aerotech will provide an on-site Field Service Representative in a reasonable amount of time, provided that the customer issues a valid purchase order to Aerotech covering all transportation and subsistence costs. For warranty field repairs, the customer will not be charged for the cost of labor and material. If service is rendered at times other than normal work periods, then special rates apply.

If during the on-site repair it is determined the problem is not warranty related, then the terms and conditions stated in the following "On-Site Non-Warranty Repair" section apply.

On-site Non-Warranty Repair

If any Aerotech product cannot be made functional by telephone assistance or purchased replacement parts, and cannot be returned to the Aerotech service center for repair, then the following field service policy applies:

Aerotech will provide an on-site Field Service Representative in a reasonable amount of time, provided that the customer issues a valid purchase order to Aerotech covering all transportation and subsistence costs and the prevailing labor cost, including travel time, necessary to complete the repair.

Service Locations

<http://www.aerotech.com/contact-sales.aspx?mapState=showMap>

USA, CANADA, MEXICO

Aerotech, Inc.
Global Headquarters

CHINA

Aerotech China
Full-Service Subsidiary

GERMANY

Aerotech Germany
Full-Service Subsidiary

TAIWAN

Aerotech Taiwan
Full-Service Subsidiary

UNITED KINGDOM

Aerotech United Kingdom
Full-Service Subsidiary

Appendix B: Revision History

Revision	Description
2.00	General update
1.05	Updated Electrical Specifications and Installation with new motor specifications.
1.04	Revision changes have been archived. If you need a copy of this revision, contact Aerotech Global Technical Support.
1.03	
1.02	
1.01	
1.00	

This page intentionally left blank.

Index

	2			E	
2006/42/EC	13		Electrical Installation		47
2011/65/EU	13		EN 60204-1 2010		13
			EN ISO 12100 2010		13
			EU 2015/863		13
		A		F	
Accuracy and Temperature Effects	20		Feedback Specifications		52
air			field service		57
nitrogen	45		Focal Lens		43,58
Air Requirements	45			H	
Altitude	20		Handling the Scan Head		26
Ambient Temperature	20		Housing Type		17
Attaching the Focal Lens to the Scan Head	43		Humidity		20
attenuator	11			I	
		B			
Basic Specifications	21		Inspection		57
Beam Entry Orientation	17		Inspection Schedule		57
beam shutter	11		isopropyl alcohol		57
		C		L	
Cable Part Numbers	50		label		26
chiller	46		lubrication		57
Class I	9		Lubrication		57
Class II	9			M	
Class IIa	9		Maintenance		57
Class IIIa	9		maximum permitted radiation value		10
Class IIIb	9		Motor Specifications		52
Class IV	9		mounting surface		
cleaning			cleaning		41
mounting surface	41			N	
solvents	57		nitrogen		45
Cleaning	57			O	
Cleaning Solvents			Optical surfaces contaminated		58
Recommended	57		Ordering Options		17
cleaning the turning mirrors	59				
compressed air	45				
coolant	46				
		D			
Dimensions	27				
Directive 2006/42/EC	13				

P

part number	26
Protection Rating	20
Protective Glass	58
protective ground connection	8,48

S

Securing the Scan Head to the Mounting Surface	41
serial number	26
Service and Inspection Schedule	57
solvents	57
stabilizing stage	26
stage	
stabilizing	26

T

Table of Contents	3
Temperature Effects	20
Turning Mirrors	59

U

Unpacking and Handling the Scan Head	26
--------------------------------------	----

V

Vacuum Operation	23
Vibration	20

W

Warranty and Field Service	61
Water Requirements	46